

# Research and development of plateau portable landslide detection equipment based on Jetson Nano

Jianguo Xu<sup>1, a</sup>, Siwei Cheng<sup>1, b</sup>, Libin Su<sup>1, 2, c</sup>, Yonggang Guo<sup>1, d</sup>

<sup>1</sup> College of Civil Engineering and Water Conservancy, Xizang Agriculture and Animal Husbandry College, Nyingchi, Xizang 860000, China

<sup>2</sup> Research Center of Civil, Hydraulic and Power Engineering of Tibet, Linzhi 860000, China

<sup>a</sup> 2642003156@qq.com, <sup>b</sup> 1557975698@qq.com, <sup>c</sup> 174693701@qq.com, <sup>d</sup> 1960373107@qq.com

**Abstract.** In response to the problems that landslides occur in remote locations, are difficult to monitor and landslide target detection is not easily deployed at the embedded end, a landslide detection device based on the Jetson nano edge device is developed. The technology detects information of landslide feature objects through YOLOV5m technology, and is able to output landslide area information as well as geographic location information while accurately detecting landslide targets. A dataset of 25,000 landslide images is used to build the data set, and the training and validation sets are divided 9:1. A deep learning network is used to extract landslide features and build a landslide target detection model. After that, the train.py file is placed on the cloud server for training, and the best.pt file is migrated to Jetson Nano and tested on the embedded platform. The experimental results show that the average running time of single frame of YOLOV5m model in the embedded device is 100ms, and the detection accuracy can be maintained above 80%, which can achieve accurate detection and information acquisition of landslide target on Jetson Nano device, and lay the foundation for the development of edge device module for landslide detection later.

**Keywords:** Machine Learning; Convenience Devices; Jetson Nano; Landslide Detection.

## 1. Introduction

The southeast region of Tibet is located in the area where the inland Marine glaciers are concentrated, and the climate is relatively complex, which is one of the regions with the most serious sudden disasters such as debris flow and landslide. The natural environment in the area is harsh, the monitoring network and stations are insufficient, the disaster investigation and monitoring are difficult, and the equipment and personnel suitable for geological disaster detection in the area are insufficient[1]. Moreover, because the landslide itself has certain safety risks, it will pose a greater risk to the equipment and testing personnel. flushbonading ARM[2]Compared with the general SCM / PLC has higher computing power and control ability, introducing it as the control system of equipment, can greatly improve the stability of the control program and processing power, to meet the technical requirements of landslide detection and area calculation.

In recent years, with the rise of machine learning technology and the continuous development of computer vision, Sun Deliang et al[3]Using logistic regression, artificial neural network and random forest model. In order to improve the real-time detection of landslide danger, Lin Kun, Ding Yong et al[4]The displacement of the landslide markers is recognized by machine vision, and the image binarization is processed by the matching of the lattice coordinate system. Wang Qingguo et al[ 4-5]Using uav-assisted scanning technology, combined with three-dimensional point cloud data and ground three-dimensional laser scanning detection, the time-consuming,

inefficient and blind spot monitoring problems of traditional monitoring technology are solved. This kind of method can easily detect the deformation trend and characteristics of landslide, and can accurately calculate the area information of landslide, but there are problems of hardware cost and high requirements for the technical level of operators. Therefore, how to realize the effective

monitoring of the landslide and the rapid positioning and area estimation after the landslide is the urgent technical problem to be solved at present.

With the continuous advancement of deep learning research, the relevant deep learning detection algorithm provides help for landslide detection. Faster RCNN The algorithm is one of the representative ones of the deep learning two-stage object detection algorithm. This algorithm is widely used in the field of target detection and has received attention and recognition by a large number of researchers. And Shaoqing Ren et al[6]It is proposed that the region generation network module (RPN, Region Proposal Network) RPN is a full convolutional network, which can predict the object boundary of each position at the same time, so as to improve the accuracy of target detection. Therefore, many scholars apply it to the detection of landslides. However, compared to the dual-stage target detection algorithm, the end-to-end single-stage target detection algorithm is more efficient, and the main widely used algorithms are YOLO series.

Yolov5[7] The target detection algorithm adopts a four-stage structure based on a deep convolutional neural network, including the input layer, backbone network, feature fusion network, and output layer. Among them, the backbone network aggregates and extracts image features at different image scales to establish feature pyramids and provide basic support for subsequent target detection. In order to combine the feature information of multiscale and multilevel and improve the accuracy and robustness of object detection. The output layer in the target detection algorithm is mainly responsible for predicting the image features, generating the bounding box and predicting the categories. Yolov5 The target detection algorithm is divided into four versions, and the main difference between the different versions lies in the depth and width setting of the model setting. In this paper, a lightweight algorithm, Yolov5M is selected as the detection network.

Based on computer vision, combining image processing and sensor, and adopting the relevant theories and techniques, this paper designs a convenient detection hardware equipment to calculate the landslide area by detecting the distance between the landslide and the instrument[8], And to verify the accuracy and practicability of the equipment through field visits.

## **2. Hardware design of the testing equipment**

### **2.1. System hardware structure design**

The design purpose of this paper is to give a lightweight design for landslide non-contact long-distance monitoring application. Therefore, in the overall design, the computing power of embedded edge detection equipment is fully considered to reduce the weight of the equipment, and we choose the remote contactless detection algorithm based on computer vision according to the major security threat of landslide monitoring itself. The algorithm can effectively realize the detection and identification of the target, and has the advantages of no contact with the target and no human intervention.

The hardware of the system mainly realizes three functions: 1. In the initial stage of the system, the modules with different functions are called by combining the key listening program; 2. Identify the characteristics of computer vision and video streaming.3. Locate the position of the equipment through the GPS module, and transmit the information of longitude and latitude and height to the video stream, so as to realize the accurate positioning and recording of the landslide position. The structure diagram of the convenient detection equipment is shown in Fig. 1.

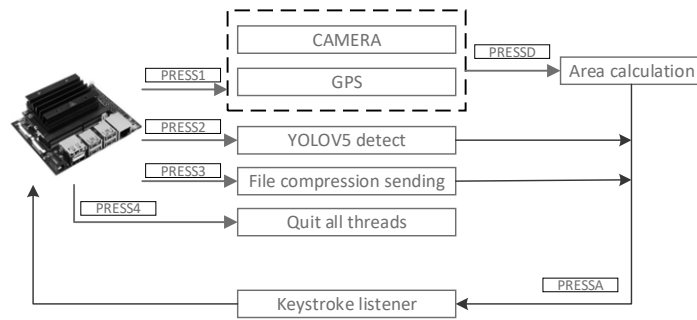
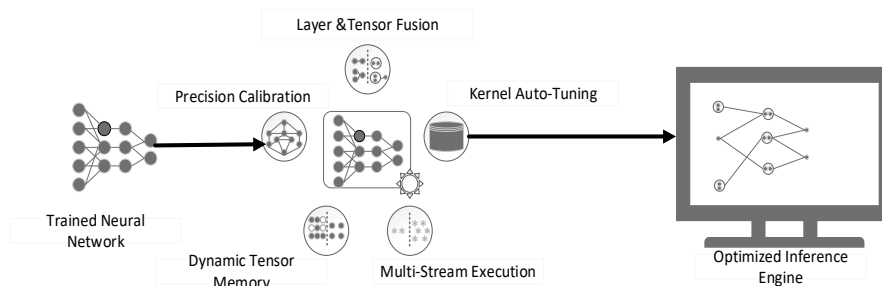

**Fig. 1** Structural block diagram of the convenient detection equipment

## 2.2. Structural framework of Jetson nano

Jetson Nano Is NVIDIA launched small GPU computing platform, Nano's biggest feature is that it contains a 128 core GPU based on Maxwell architecture, as an embedded device, can use it to achieve some small-scale, and optimized network model reasoning, its provides 40 pin extension port, connect the USB port of various hardware, ethernet port for wired network transmission and used to connect display HDMI interface and DP interface. Nano supports a variety of syntax and AI frameworks, such as SSD, YOLOV5, PyTorch, etc., which can realize target detection, image recognition, road detection, and multi-target tracking and other functions, which is suitable for low cost, large detection targets, many detection targets, small development structure and other fields.

Compared with the hardware design of raspberry Pi, Jetson Nano has a small size, strong performance and high cost performance. And its computing power is specially developed for robots and artificial intelligence, which is more powerful than the Raspberry Pi. In this paper, TensorRT optimizer is adopted in the deployment and reasoning of neural network to accelerate the reasoning of neural network. By eliminating unused layers and the fusion of convolution, paranoia and ReLU operations, the neural network can be better deployed to Jetson Nano and improve the computing speed and real-time detection frame rate, The structure diagram is shown in Fig. 2.

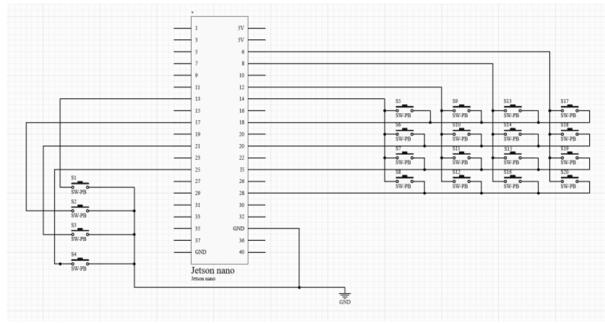

**Fig. 2** TensorRT Work flow chart

## 2.3. Design of the key-circuit module

The key-circuit module plays an important role in the calling program system. Without a schematic design and breadboard testing, this module may cause a system failure.

In the process of key selection, the plastic buckle button with 16MM is selected. When the key is pressed, a low level signal is generated and transmitted to the board through the GPIO port of Jetson Nano and Jetson Nano. Nano will analyze the electrical signals transmitted by the GPIO port and call the subroutines of the corresponding serial port to achieve different functions, The structure diagram is shown in Fig. 3.

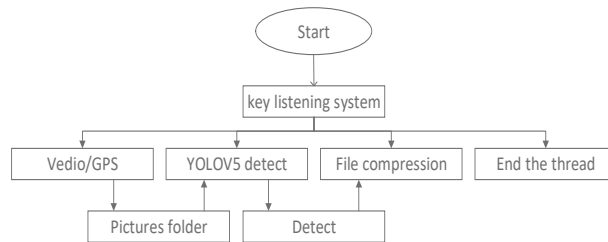

**Fig. 3** Schematic diagram of the key button circuit

### 3. Software programming of the testing equipment

#### 3.1. Software program design of the testing equipment

The program of portable detection equipment uses YOLOV5 algorithm to detect the landslide in the picture. In the main loop, the camera data was first read and the image was scaled to 640pixels \* 480pixels. The GPS then transmits the information to the terminal and according to the NMEA018 protocol format[8]Through the conversion, the information obtained by the GPS conversion is transmitted to the video stream through the cv2.putText function in the Opencv, so that the pictures with the geographical location coordinates can be obtained. The function of area calculation was calculated using the principle of small hole imaging. The function of file compression and transfer uses the smtplib function in the Python library to send the files. The specific flow chart is shown in Fig. 4.



**Fig. 4** Flow diagram of the main program

#### 3.2. Calculation of the landslide body area

Camera parameters are important fundamental concepts in computer vision, used to describe the internal characteristics and external poses of the camera[12]. During camera calibration, camera parameters need to be accurately measured in order to accurately obtain information on the position and morphology of 3D objects during subsequent computer vision tasks. Zhang Zhengyou checkerboard method is a widely used in camera calibration method, its advantages are simple, high accuracy, and does not need any special equipment. This method uses a special checkerboard and obtains the checkerboard image at different angles to extract the checkerboard corners through the corner point detection algorithm to calculate the internal parameters and external attitude of the camera. Therefore, this paper will introduce the basic principles and procedures of Zhang Zhengyou's checkerboard method [10-13], And the experimental results are presented to verify its feasibility and accuracy.

#### 3.3. Nonlinear camera model

Compared with the linear camera model, the nonlinear camera model is not in the same straight line in its own lens, image plane, main optical axis and sensor, so there is generally a certain distortion in the actual imaging process. Tangential distortion is a kind of perspective distortion, which occurs when the lens and the image plane are not completely parallel. Generally, it is caused by errors in the manufacturing and assembly process of the lens. Radial distortion refers to the deformation of the

image in the edge area of the lens. Its principle is that when the lens is imaging, the light in different positions passes through different degrees of refraction and scattering, resulting in the offset of the focus position of the light, so that the actual position of the pixel point and the expected position are inconsistent.

The nonlinear model of the camera lens is:

$$\begin{cases} x_{distorted} = x(1+k_1r^2+k_2r^4+k_3r^6) + 2p_1xy + p_2(r^2+2x^2) \\ y_{distorted} = y(1+k_1r^2+k_2r^4+k_3r^6) + p_1(r^2+2y^2) + 2p_2xy \end{cases} \quad (1)$$

$r = \sqrt{x^2 + y^2}$  It represents the distance of the object point in the camera frame to the light center, and represents the coordinates of the object point in the camera frame.  $x, y, k_1, k_2$  Is the radial distortion parameter and the tangential distortion parameter.  $P_1, P_2$

### 3.4. Nonlinear camera model

In terms of camera calibration, by calling the library function files in OpenCV, the user can easily obtain the camera parameter files and related functions, rather than complex mathematical formulas[14].

OpenCV Combined with the plane calibration method proposed by Professor Zhang Zhengyou in 1998, we developed a set of calibration algorithm. The algorithm mainly solves the problem of picture distortion caused by radial distortion and tangential distortion, and can solve the internal parameters and external parameters of the camera.

### 3.5. Nonlinear camera model

$M(X, Y, Z)^T$  For the object point under the three-dimensional spatial coordinate system, the projection coordinate on the image plane is, assuming that the internal parameter matrix of the camera is, and the external parameter matrix is, where the rotation matrix is the translation vector, there are the following relationships:  $m(x, y)^T = A[R | t] R^t$

$$A = \begin{bmatrix} f_x & s & c_x \\ 0 & f_y & c_y \\ 0 & 0 & 1 \end{bmatrix} \quad (2)$$

$f_x, f_y, s, c_x, c_y$  Where the focal length of the camera in the image level and vertical direction, respectively, indicates the tilt of the image, and is the coordinates of the main point of the camera in the image coordinate system. The rotation and translation of the camera can be represented by the external parameter matrix, transforming the points on the object coordinate system to the camera coordinate system, and the coordinate transformation can be expressed as:  $M(X, Y, Z)^T$

$$\begin{bmatrix} u \\ v \\ w \end{bmatrix} = \begin{bmatrix} r_{11} & r_{12} & r_{13} \\ r_{21} & r_{22} & r_{23} \\ r_{31} & r_{32} & r_{33} \end{bmatrix} \begin{bmatrix} X \\ Y \\ Z \end{bmatrix} + \begin{bmatrix} t_x \\ t_y \\ t_z \end{bmatrix} \quad (3)$$

$\begin{bmatrix} r_{11} & r_{12} & r_{13} \\ r_{21} & r_{22} & r_{23} \\ r_{31} & r_{32} & r_{33} \end{bmatrix}$  Where is the rotation matrix,  $[t_x, t_y, t_z]^T$  which is the translation vector. Proting a point

on the camera coordinate system to the image plane and get the point, the coordinate of the point in the image coordinate system is:,. Combining the above transformation relationship, we can obtain the

projection model of the camera, namely the basic mathematical formula of the camera model. For a point in a known object coordinate system, its projection position on the image is, which can be calculated by using a mathematical formula, as follows:  $M(X, Y, Z)^T$

$$\begin{bmatrix} x \\ y \end{bmatrix} = f\left(\begin{bmatrix} X \\ Y \\ Z \end{bmatrix}, K, R, t\right) \quad (4)$$

$K$   $R$   $t$  Where are the internal parameter matrix of the camera, and are the rotation matrix and the translation vector of the camera, respectively. In practice, the camera calibration method is usually used to compute the matrix,, and then calculate the two-dimensional projection coordinates on the image plane through the given 3 D point coordinates of the object.  $K$   $R$   $t$   $M[x, y]$

### 3.6. Nonlinear camera model

According to the calibration process of the OpenCV camera, the operation process of the system is formulated, as shown in Fig.5.

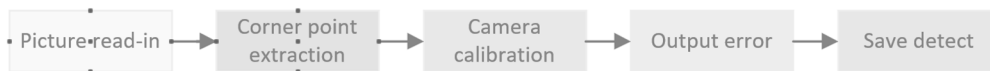

**Fig. 5** System operation flow chart

First, you need to design a checkerboard picture with a number of 10 \* 10, each square with a size of 2mm. The edges of these squares form some characteristic points also called corner points. These corner points can be used to calculate the internal parameters and external poses of the camera. Then, the image of the checkerboard is taken at different angles and the pixel coordinates of the checkerboard corners are extracted, and the angular point detection algorithm is used to implement this process. Then, by calculating the relationship between the geometry of the checkerboard model and the camera model, a calibration algorithm is used to calculate the internal parameters and the external attitude of the camera, where the corner points are plotted as shown in Fig.6. Finally, the calibration results are detected, including the camera calibration error and reprojection error and related indicators, to verify the accuracy and reliability of the calibration results.

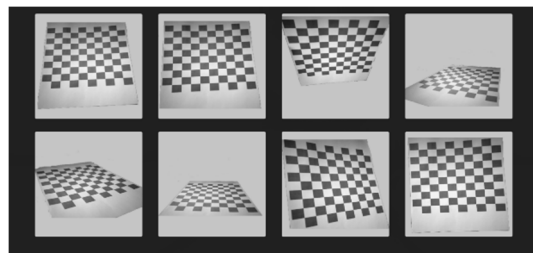

**Fig. 6** corner plot plot

### 3.7. Principle of calculating the area of small holes

The size calculation of the object partially refers to the small hole imaging[15]The sensor can generate a digital image by recording the intensity and location of the light reflected from the object's surface. From these digital images, some details of the object surface can be extracted, so that the size calculation can be performed. Specifically, the actual size of the object can be calculated using certain features of the surface, such as edges, corners, etc. In addition, the actual size of the object can also be calculated by measuring the projection size of the object on the image plane and the distance between the image plane and the object. According to the projection principle of the two-dimensional image plane and 3 dimensional scene of the camera, as well as the small hole imaging model, the following relationships can be obtained:

$$Z_c \begin{bmatrix} x \\ y \\ 1 \end{bmatrix} = \begin{bmatrix} f & 0 & 0 & 0 \\ 0 & f & 0 & 0 \\ 0 & 0 & 1 & 0 \end{bmatrix} \begin{bmatrix} X_c \\ Y_c \\ Z_c \\ 1 \end{bmatrix} \quad (5)$$

$f(x, y)$  ( $X_c, Y_c, Z_c$ ) Is the focal length of the camera, the physical characteristic point in the corresponding plane, and the coordinates of the corresponding point in the coordinate system of the camera.

### 3.8. GPS information acquisition and output function

First, to obtain the GPS [16] The serial port information needs to be communicated by the serial port, and the UTC time information and latitude and longitude information can be obtained, and then the data can be transmitted to the Jetson board through the USB interface, and finally the location information can be obtained through conversion in the code.(5th Edition Changes)

The GPS information is integrated into the video frames by using the OpenCV. This method outputs the GPS information to the video frames by using the cv2.putText function. The cv2.putText function allows for text to be added at a specified location in an image or video frame, and its function library has various font, size, color, and other format parameter options. Try different font sizes and color combinations to optimize the readability of the text so that the GPS data and time area information can be clearly seen in each image saved.

### 3.9. Yolov5 Detection box

Yolov5 Is a popular object detection framework that can quickly and efficiently detect objects in an image and give them to its bounding box[17]. The framework employs a Anchor-based target detection method to achieve target detection by predicting whether each Anchor box contains the target object in the image as well as the category and bounding box position of the target object. The specific process is as follows. First, the input images are processed by the convolutional neural network (CNN) to extract a series of feature maps. Then, for each pixel spot on the feature map, Yolov5 generates a set of Anchor boxes to represent the regions that may contain the target. For each Anchor box, the Yolov5 predicts whether it contains the target object as well as the category and bounding box position of the target object. Finally, judging from these prediction results, Yolov5 can determine the location and category of all target objects in the image. In contrast to traditional target detection methods, Yolov5 uses the Anchor box to predict target locations rather than directly on the feature map. This method can locate the target more accurately and can avoid detection errors caused by the target position being too close to the edge of the feature map. In addition, Yolov5 also uses multi-scale prediction and non-maximum suppression (NMS) technologies to further improve the detection accuracy and speed.

Moreover, the framework adopts a feature fusion method based on attention mechanism, which makes better use of different levels of feature information to improve detection accuracy. Yolov5 Has multiple advantages, making it one of the most popular object detection frameworks. First, it has a very high detection accuracy and speed, which can achieve fast target detection while ensuring the detection effect. Secondly, Yolov5 can automatically identify the category of the target object without manual annotation, which reduces the workload of annotation data. Furthermore, Yolov5 can be adaptive to different input resolutions and able to handle targets at different scales. Yolov5 Target detection algorithm is based on deep learning technology, and its mathematical model is an important guarantee for its high accuracy and high efficiency. In terms of feature extraction, Yolov5 adopts the Darknet53 network and combines modules such as SPP and PAN to improve the feature extraction ability.

Specifically, the mathematical model of Yolov5 can be expressed as follows:

$$G_{IOULOSS} = 1 - (I_{OU} - \frac{|C - (A \cup B)|}{|C|}) \quad (6)$$

In terms of the accuracy of image recognition, the accuracy rate (Precision) and the recall rate (Recall) are the two most intuitive indicators to judge the accuracy of the model training, in which the calculation formula is as follows:

$$\text{Precision} = \frac{TP}{TP + FP} \quad (7)$$

$$\text{Recall} = \frac{TP}{TP + FN} \quad (8)$$

In the above formula: TP is the number of samples divided into ontology positive samples; FP is the number of non-ontology samples divided into ontology samples; and FN is the number of ontology samples classified into non-ontology samples[15]

#### 4. Experiments and analysis

Edge computing mode has the characteristics of distribution, high efficiency, low latency and low cost[18]Distributed deployment of data processing tasks and edge computing mode can relieve the computing pressure of data center and ensure the security of data. However, a difficulty in edge computing is how to optimize the model structure to facilitate running the algorithm on devices with low computational power.

In this paper, Yolov5 algorithm is used to analyze and extract the landslide information. Through experiments, it is found that Yolov5 algorithm can realize real-time detection with the help of hardware equipment, and the detected information can be compressed and transmitted to researchers through local software.

As shown in Fig. 8 and Fig. 9, they are the results of Yolov5m operation detection, where the red box is the landslide body, and the number above shows the corresponding confidence degree. The completed file will be sent to the preset mailbox in real time after the user presses the button.



Fig. 7 Landslide test 1



Fig. 8 Landslide test 2

#### 5. Conclusion

To sum up, the unique regional geological environment in southeast Tibet is easy to breed high and remote landslide geological disasters, which has become a major engineering geological problem to be solved urgently. The impact of high long-distance landslide on environmental safety in southeast Tibet has attracted wide attention. The mountainous landforms of southeast Tibet are characterized by large longitudinal slope of the riverbed, narrow and deep valleys, rapid current, and hillside side erosion, which aggravate the erosion and destruction of the mountain. Under the action of various factors such as earthquake, rainfall, groundwater and human engineering activities, the skid resistance of the quaternary huge thick loose accumulation body was gradually weakened, leading to the occurrence and development of landslides. This type of landslide is extremely destructive and has a very serious impact on the surrounding environment.

China is rich in glacier resources, among which the Qinghai-Tibet Plateau and its surrounding areas are the main distribution areas of glacier resources. The rapid change of glaciers not only affects the stability of the glaciers themselves, but also increases the risk of glacier disasters. The cause of glacial lake collapse is closely related to glacier change, climate change, and crustal movement. In the Qinghai-Tibet Plateau area, the risk of flood disaster caused by glacial lake collapse is increasing day by day, and the importance of glacial lake flood control work cannot be ignored. Therefore, efficient monitoring equipment needs to be used to predict and deal with the glacial lake collapse. In addition, the equipment proposed in this paper can also be used to detect debris flows caused by glacier collapse, which can give timely warning to reduce casualties and property losses in downstream areas.

Due to low power consumption, high cost performance and simple maintenance, landslide detection of embedded devices can further reduce the cost; but its average computing performance, small memory bandwidth and on-chip cache cannot operate as easily as high-performance computers. In order to highlight the advantages of high cost performance of embedded equipment, the landslide detection system suitable for embedded equipment. This paper describes a convenient landslide detection equipment based on edge equipment. Using Python as the development language, GPS module, GPIO module and camera module as the support of the system, the detection of landslide body and the estimation of landslide area, which is convenient for researchers to timely record data and make relevant professional analysis of the post-disaster loss assessment. It is of great engineering value by providing early warning of landslides and reducing the losses caused by disasters.

## References

- [1] Han Shunshun. Evaluation of geological disaster susceptibility in southeast Tibet [J]. *Journal of Mountain Studies*, 2021,39 (05): 700.
- [2] Li Hongfei, Hu Manhong. Research on real-time intelligent obstacle avoidance system of picking robot- -based on embedded ARM [J]. *Agricultural Mechanization Research*, 2021,43 (04): 107-111
- [3] Sun Deliang. Research on landslide prone zoning and rainfall-induced landslide [D]. East China Normal University, 2019.
- [4] Lin Bo Kun, Li Denghua, Ding Yong, Li Yuanmeng. Research on nighttime uninterrupted monitoring technology of landslide body based on machine vision [J]. *Laser magazine*: 1-6.
- [5] Wang Qingguo, Zhao Hai, Li Jianping. Landslide monitoring by combining ground laser point cloud and aerial image [J]. *Surveying and mapping Bulletin*, 2019 (04): 99-102.
- [6] REN S, HE K GIRSHICKR, et al.Faster R-CNN:towards real time object detection with region proposal networks[J].*IEEE Transactions on Pattern Analysis and Machine Intelligence* , 2017, 39(6):1137-1149
- [7] Jochen YOLOv5:The Leader in Realtime Object Detection[EB/OL].ar Xiv:1804.02767v1.2018
- [8] Zhang Guolong, Wang Tonghe, Ji Siyuan. Application of three-dimensional laser scanning measurement technology in the overall monitoring of landslide [J]. *Engineering Survey*, 2017,45 (07): 54-58.
- [9] Long Shike, Jiang Qihang, Bao Yunan, Wang Jianqi. Design based on the Jetson Nano vision application platform [J]. *Sensors and Microsystems*, 2022,41 (09): 99-101 + 108.
- [10] Lian Xiaofeng, Dou Lihua, Chen Jie. Research on the calibration method of omni-directional camera [J]. *Optical Technology*, 2008 (01): 75-78.
- [11] Tang Yi, Chen Xi, Liu Xianglei. Application of OpenCV's camera calibration in high-speed cameras [J]. *Beijing Surveying and Mapping*, 2018,32 (05): 578-582
- [12] Huang Jilan, Lou Xinyuan. Testing practice of monocular camera calibration based on OpenCV [J]. *Railway computer application*, 2009,18 (04): 47-49.
- [13] Wang Tan, Wang Leilei, Zhang Weiguo, Duan Xiaotao, Wang Wanli. Infrared target system based on Zhang Zhengyou's calibration method [J]. *Optical Precision Engineering*, 2019,27 (08): 1828-1835.
- [14] Zhang Z Y.A flexible new technique for camera calibration[J].*IEEE Transactions on Pattern Analysis and Machine Intelligence*, 2000, 1:201-207.
- [15] HRUSNA C S, VEENA M B, KESHINHA R G D.OpenCV Implementation of Grid-based Vertical Safe Landing for UAV using YOLOv5[J].*International Journal of Advanced Coter Science and Applications (IJACSA)*, 2022, 13(9):325-334.
- [16] XiangYong, Wang Zhangrui, Xu Fanghua, Zhang Linxin. GPS navigation data extraction and coordinate transformation [J]. *Instrumentation User*, 2009,16 (04): 70-71.

- [17] Zhen Ran, Liu Ying, Meng Fanhua, Zhu Jintai. Lightweight target detection algorithm based on YOLOv5 [J / OL]. Radio engineering: 1-9 [2023-04-04].
- [18] DENG S, ZHAO H, FANG W, et al. Edge intelligence: the confluence of edge computing and artificial intelligence[J]. IEEE Internet of Things Journal, 2020, 7( 8) : 7457-7469.