

# Research on on-site installation process of grinding roller of SLM5600 Vertical roller mill

Shiyong Zhang<sup>1</sup>, Defang Zou<sup>1</sup>, Jiacan Xu<sup>1</sup>, Xu Li<sup>1</sup>, Yue Zhai<sup>2</sup>, Bo Song<sup>3,\*</sup>

<sup>1</sup> Shenyang Jianzhu University, Shenyang, Liaoning, China

<sup>2</sup> Shenyang Elysan Electronic Technology Co. Ltd, Shenyang, Liaoning, China

<sup>3</sup> Ccteg Shenyang Engineering Company, Shenyang, Liaoning, China

\*Corresponding Author: Bo Song

---

## ABSTRACT

SLM5600 vertical roller mill is widely used in 6000t/d cement clinker production line, the main parts of SLM series mill is a whole disc and three grinding roller, the roller in addition to the regular change with the liner accident, also need to regularly check and change with the bearing and oil seal and the wear bushing, by SLM5600 roller mill Department of heavy cement plant machinery maintenance conditions are limited, many manufacturers can only be shipped back to my company roller for repair and replacement parts, resulting in long period of maintenance, repair costs, provide a set of field assembly roller assembly process in this paper, according to the process maintenance workers on-site replacement parts and grinding roller assembly.

## KEYWORDS

SLM5600 vertical roller mill; Grinding roll; On-site installation; Assembly process

---

## 1. INTRODUCTION

SLM5600 Vertical grinding is a raw material designed for 6000t/d cement clinker production line. The middle diameter of the grinding area is 4.5m, the outer diameter of the grinding area is 5.6m, and grinding plate is 6.1m, which is the largest concentrated loading raw material in China at present. The specific structure is shown in Figure 1.

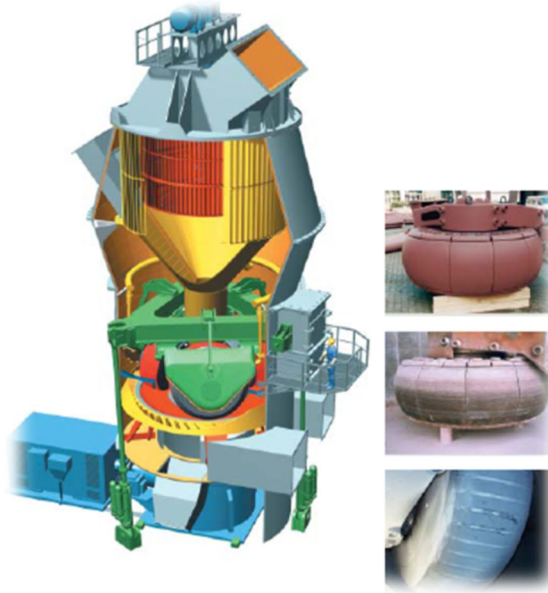

**Figure 1.** SLM vertical grinding structure

As the main grinding part of the mill, the mill works under heavy load, high temperature and wind erosion, and the damage occurs due to inadequate daily maintenance or emergencies. When there are serious cases such as the damage to the rotating oil seal and the grinding roller bearing damage, it is necessary to remove the grinding roller and replace the damaged parts. At present, there are few studies on the field assembly method of grinding rollers, and the research mainly focuses on repair and maintenance[1-3]. This paper introduces the installation points of SLM5600 vertical mill roller for the reference of this model and other SLM mill users.

## **2. PREPARATION BEFORE THE INSTALLATION**

According to the grinding roller assembly drawing, classify the disassembled grinding roller parts to be replaced, and determine whether the size of the newly purchased spare parts is correct, and whether the model meets the requirements of the grinding roller drawing, as shown in Figure 2.

Check the matching size of the key parts of the grinding roller, check and clean the chamfering of all parts, residual dirt, etc., otherwise it shall not be assembled.

All O-rings shall be coated with glycerol grease before loading.

Prepare the grinding roller section assembly drawing.

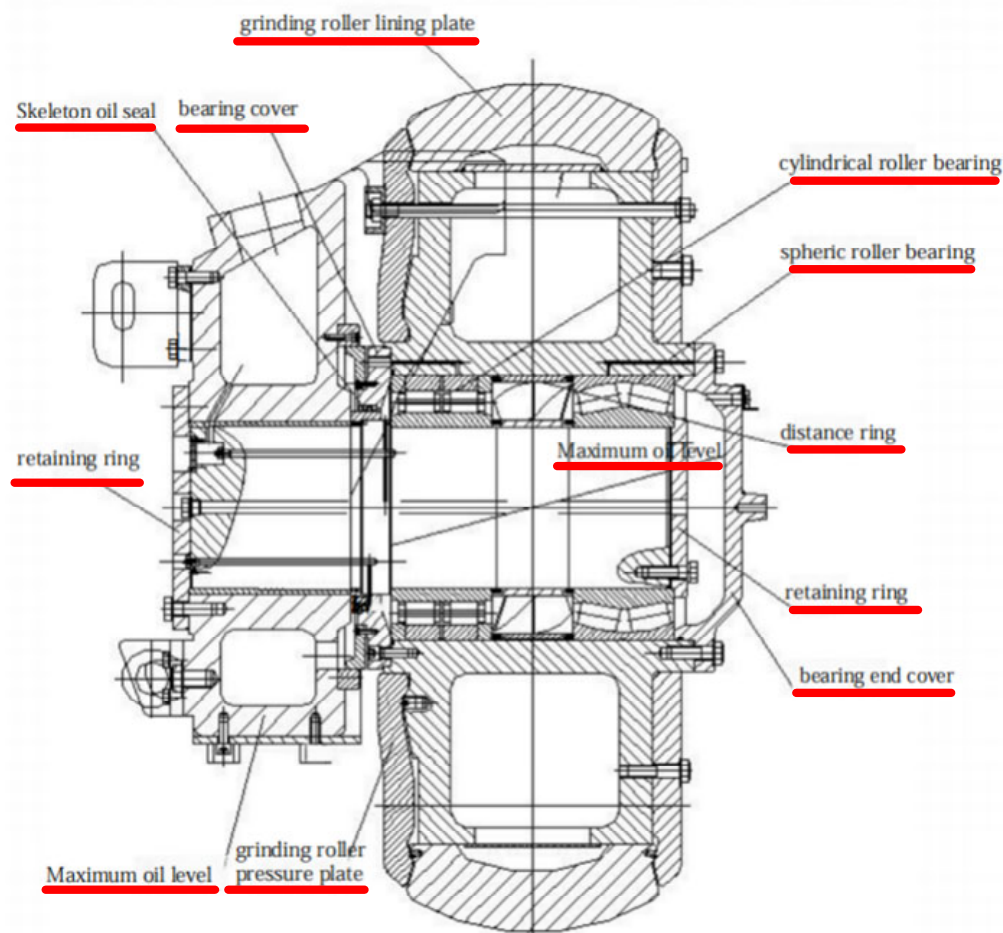

**Figure 2.** Structural diagram of the grinding roller

### 3. ASSEMBLY OF THE SHAFT AND THE BEARING

Select a clean and flat assembly site, and place the neat and inspected qualified grinding roller shaft immediately on the assembly site, with the cone shaft end facing down.

Heat the cylindrical roller bearing inner ring to 80-90°C with the shaft. The end surface of the bearing inner ring shall be close to the shaft shoulder end face. The inner ring and the outer ring are then assembled sequentially.

Heat the spherical roller bearing to 79-90°C, then heat it with the shaft and assemble the positioning stop.

Note that the handles and bolts should be tightened symmetrical and evenly, and the tightening torque meets the requirements corresponding to the bolt specifications and model. During the cooling process, the handles and bolts should be tightened several times until the axial gap due to cooling contraction is eliminated after cooling.

After the two bearings naturally cool to the ambient temperature, turn the shaft by 180° and assemble the outer ring and ball holder of the cylindrical roller bearing in place.

### 4. ROLLER ASSEMBLY

Check that the oil holes of the roller body are smooth without blockage.

Put the small end of the roller body flat on the three equal metal release box, the height of the square box should be less than 500mm, heat the hole in the roller body evenly, do not keep the flame directly sprayed to the surface of the hole in the roller body, and the upper end of the roller body is covered with steel plate for insulation.

Observe the heating condition of the inner hole and measure the temperature every 5 minutes with a temperature measuring gun. When the hole in the roller is heated to 130-170°C, put the shaft and bearing assembly into the roller body vertically, adjust the upper end surface of the cylindrical roller bearing at the same plane at the bottom jack of the shaft, and smoothly position the grinding roller shaft assembly at the lower plane with the jack.

The roller is stand when the roller body is cooled to the ambient temperature.

Apply the O-ring with glycerol and pre-assemble it to the bearing cover.

Assemble the bearing cap and the O-shaped sealing ring together with the roller body, and tighten the closing bolts. Note that the tightening torque of the bolts meets the specifications of the bolts.

Stand the roller on the side, install the bearing cover on the other side, and then pad the square box to restore the roller to the upright state.

Install the wear-resistant bushing, note that the positioning pin should be aligned with the positioning groove on the grinding roller shaft, the oil hole of the wear-resistant bushing should be aligned with the oil hole on the grinding roller shaft, and the wear-resistant liner oil outer ring should be coated with lubricating grease.

The O-type sealing ring is coated with glycerin and pre-assembled into the sealing groove at the end surface of the roller body. Apply lubricating grease on the inner and outer circular arc surface of the rotating oil seal, apply lubricating grease on the inner surface of the bearing cap and introduce the mounting ring of the rotating oil seal into the bearing cap.

Combine the bearing cap with the roller body.

## **5. GRINDING ROLLER PRESSURE TEST**

Install the pressure test tool at the central screw hole of the roller shaft and block the pressure relief hole and oil hole at the shaft end. All connecting parts must be well sealed without leakage.

Then pass into the dry and clean air source, the test pressure must reach 0.05MPa, hold the pressure for 30 minutes, during which the allowable pressure drops to 0.025MPa. If the pressure drop in 30 minutes is greater than 0.025MPa, it is necessary to apply the method of soapy water to find the leakage point. The leakage point may be caused by the casting sand hole or the poor sealing performance of the sealing ring.

After plugging the leakage point, do the pressure test again until the next assembly is qualified.

## **6. ASSEMBLY GRINDING ROLLER LINING PLATE**

Cover the roller body part smoothly and firmly.

Clean the cast square socket of each grinding roller liner, check the size of the grinding roller liner, and the Angle of qualified installation.

Choose two grinding roller lining plates with large square nest size, assemble the symmetrical 180° limit plate from the roller body, press and stick firmly with the pressure plate, and mark them.

Hoist each grinding roller liner in turn and press it with the pressing plate. Check the contact gap between the grinding roller liner and the cylindrical surface of the roller, which shall be less than

0.10mm, and the accumulated gap between the 30° both sides of the grinding roller liner shall not be greater than 0.05mm.

## 7. INSTALL THE GRINDING ROLLER BRACKET

Clean the impurities in the cavity cast with the grinding roller bracket with the fan, without any residue, this part should be focused on inspection and confirmation.

Check the dimension and concentricity of the mounting hole of roller support and roller shaft.

Test the bush and the roller shaft, measure and record the initial height difference between the bush end face and the shaft end face, and ensure that the pressure amount is within  $34\pm 3$ mm, otherwise the assembly is not allowed.

Install the grinding roller holder with a sealing ring end facing down, lay flat with a high metal square box, and evenly heat the inner hole of the grinding roller holder with a gas flame. Check the heating temperature of the inner hole of the grinding roller holder and record it every 5 minutes when the inner hole is heated to 120-180°C.

Use a crane to lift the inner hole of the grinding roller support to the grinding roller bush vertically, and the height of the difference between the bush and the end surface of the two ends of the grinding roller shaft is measured by the retaining ring. Tighten the retaining bolts evenly to pressure the liner into  $34\pm 3$ mm.

Assemble the rest of the roller support and refuel the roller.

## 8. CONCLUSIONS

The above installation method for grinding rollers provides users with a simple and efficient on-site installation method, which solves the problem of cement plants not having to self-inspect grinding rollers. This method can be used for various models of SLM series vertical roller mills, and users can do this in reverse. In addition, key processes should be inspected with emphasis, and the entire assembly process should be recorded to facilitate use during the next maintenance and roll removal.

## REFERENCES

- [1] Sun Y, Sun G. Research on the online repair technology of vertical grinding roller body . Cement Engineering, 15 (3), 60–61. <https://doi.org/10.13697/j.cnki.32-1449/tu.2015.03.021>
- [2] Jiang LJ. SLM 4531 Use and maintenance points of vertical grinding roller bearings . Cement Engineering, 14 (3), 60–61. <https://doi.org/10.13697/j.cnki.32-1449/tu.2014.03.020>
- [3] Xie WA, Qu LL, Zhang SY. Development and design of MLN4250 cement vertical mill. Process equipment, 18(3), 62–65. <https://doi.org/10.13697/j.cnki.32-1449/tu.2018.03.020>