

# Design of High-efficiency Circulating Filtration System of Cutting Fluid

Shuo Jiang <sup>a</sup>, Hongchang Sun <sup>b</sup>, Yinuo Zhang <sup>c</sup>, Haonan Hu <sup>d</sup>

School of Mechanical Engineering, Tianjin University of Technology and Education, China

<sup>a</sup> 2639489323@qq.com, <sup>b</sup> 13682089320@126.com, <sup>c</sup> 2915391744@qq.com,

<sup>d</sup> 1474958093@qq.com

## ABSTRACT

In this paper, an adaptive and controlled oil bidirectional separation filter system is designed to realize the adaptive switching of the corresponding filter module according to the results of cutting fluid type, and complete the filtration process of different types of machine tools under the conversion of dual-module filter module.

## KEYWORDS

Ceramic Inorganic Film; High Strength and Toughness Steel Cutting; Filtration Performance; Bidirectional Separation and Filtration Mechanism.

## 1. INTRODUCTION

With the rapid development of modern precision machining technology, cutting fluid as the key process medium in the mechanical manufacturing process, its performance stability directly affects the processing quality and the service life of equipment. Under the background of intelligent manufacturing, multi-variety and small batch production mode puts forward higher requirements for cutting liquid treatment system. Traditional filtration devices generally adopt a single modular design, which is difficult to adapt to the differentiated treatment needs of different kinds of cutting fluid (emulsion, semi-synthetic liquid, total synthetic liquid, etc.), leading to increasingly prominent problems such as filtration efficiency fluctuation and rising maintenance cost. This technical bottleneck has become a key factor restricting the development of high-precision processing process.

## 2. MAIN INSTRUMENTS AND EQUIPMENT

In order to ensure that the filter amount of cutting fluid meets the requirements of daily machining use, the length range of the tubular membrane group used by the regular filter processor is generally 700-1200mm. However, the tubular filtration module used in daily machining has a large processing capacity, usually reaching 200 L/h, and the use of large filtration components to complete the exploration of the membrane flux change law will cause the huge consumption of cutting waste liquid, sampling difficulties and incomplete experimental results and other phenomena.

Therefore, we chose to build a small cutting liquid filter prototype to complete the membrane flux experiment and explore the loss rules of different membrane elements. The cutting fluid filter prototype is shown in Figure 1. The prototype can assemble small ceramic inorganic membrane filter elements with an outer diameter of  $\varnothing$  40mm, the length of the membrane tube is 200mm, and the membrane area is 0.11m<sup>2</sup>. Built-in pressure regulating pump to meet the 0~1.6MPa membrane

pressure inlet and reflux pressure adjustment. Among them, the maximum pure water treatment capacity of a single film of the prototype membrane device is about 65 L/h (the cutting fluid treatment capacity is adjusted according to the situation).

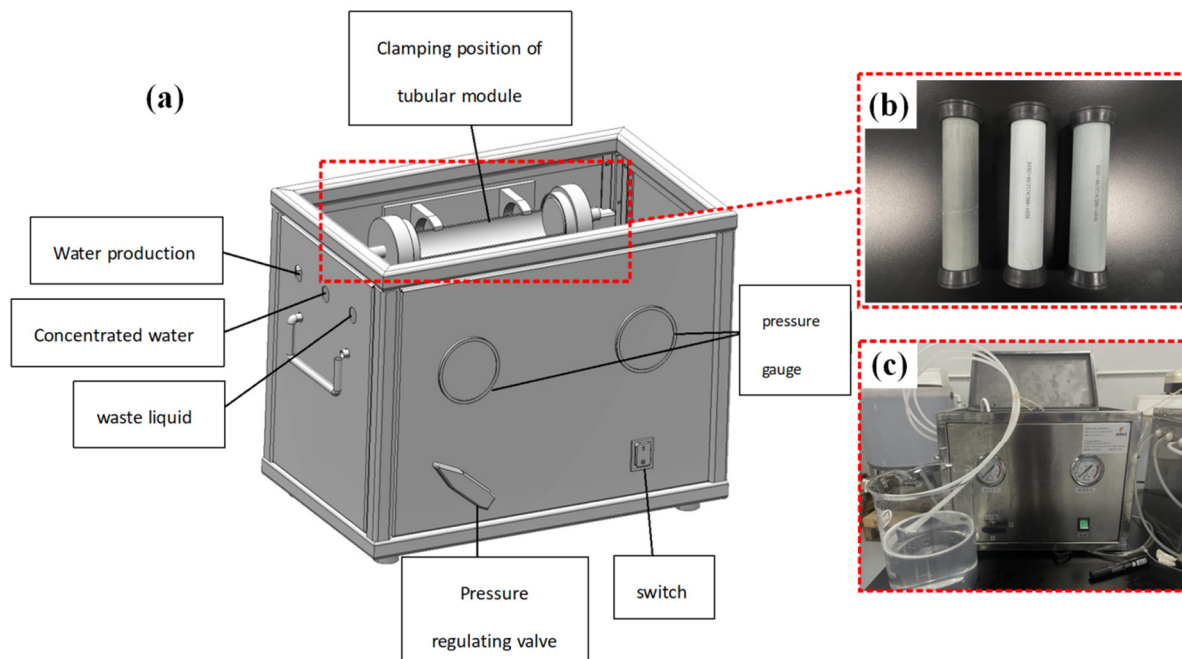

**Figure 1.** filter prototype structure and physical drawing (a) filter prototype structure; (b) filter film physical; (c) prototype physical

### 3. DESIGN PRINCIPLE OF CUTTING FLUID ADAPTIVE AND CONTROLLABLE OIL TWO-WAY SEPARATION AND FILTRATION SYSTEM

The cutting fluid adaptive controlled oil bidirectional separation filtration system is a device with efficient filtration and intelligent regulation function, used to treat solid particles and oil pollution in the cutting fluid. The system design principles should follow the following points:

1. the principle of efficient filtration: the system should adopt efficient filtration technology, combined with the aforementioned semiconductor inorganic film filtration material and control variable method, in order to realize the effective filtration of small particles and oil pollution in the cutting liquid. By optimizing the pore size and material selection of the filtration medium, the system can efficiently remove suspended particles and fine oil droplets, improving the cleanliness and stability of the cutting fluid.
2. Adaptive regulation principle: the system should have the ability to monitor and adjust parameters in real time, so as to automatically adjust the filtration speed and pressure according to the change of cutting fluid, to ensure the stable operation of the filtration system under different working conditions. Through the sensor and automatic feedback control, the system can sense the flow rate, concentration, temperature and other key parameters of the cutting fluid in real time, and independently adjust the filtration conditions according to the preset control strategy, so as to achieve the best filtration effect and energy consumption control.
3. Two-way separation principle: the system should have the function of two-way separation, which can switch the corresponding filter module according to the results of cutting fluid type, and complete the filtration process of different types of machine tools under the conversion of dual-module filter module.

4. Realize the drainage and treatment of solid particles, waste liquid and circulating liquid respectively, and reasonably plan the equipment operation pipeline sequence and liquid storage space.
5. Sustainable development principles: The system should be designed considering energy consumption and environmental impact, and adopt sustainable technologies and materials as far as possible. By optimizing the utilization efficiency of energy use, reducing waste generation and adopting environmentally friendly materials, we can reduce the environmental load of the system, and improve the sustainability and economic benefits of the system.

## 4. OVERALL STRUCTURAL DESIGN OF THE FILTER MACHINE

### 4.1. Preprocessing Mechanism

Waste liquid pretreatment mechanism including stainless steel filter tank and nano oil separation tank, stainless steel filter tank with side in bottom out (also using side in side out), filter liquid medium through the pressure in the pipe into or into the filter barrel, the filter liquid medium to punch through the filter, produce the ideal solid-liquid separation to achieve the liquid medium filter effect. Use stainless steel filter core, filter accuracy: 0.5um, used to intercept solid impurities and protect the pump and pipeline. Stainless steel coarse filter tank can protect the normal work of compressor, pump, instrument and other equipment. When the fluid flows into the filter cylinder with a certain size of the filter screen, its impurities are blocked, and the clean filter fluid is discharged from the filter outlet. When it needs to be cleaned, as long as the removable filter cylinder is removed and reloaded after processing.

The nano oil separation tank is hydrophilic and oil hydrophobic, the membrane material water passage speed, high oil separation purity, high separation efficiency, low separation cost, the product supports repeated use, the other end of the oil nano oil separation tank is connected with the other end of the oil nano oil separation tank.

### 4.2. Cutting Fluid Bidirectional Separation and Filtration Mechanism

The cutting fluid bidirectional separation filter module is a controlled hydraulic fluid bidirectional separation loop device, which includes cutting oil pipeline, cutting fluid pipeline, control bin, rotating paddle, driven gear, rotating rod, etc., as shown in Figure 3. The bidirectional separation circuit device of controllable hydraulic oil does not change the original filtration treatment conditions, but combines two independent pipelines of cutting oil and cutting fluid to realize the accurate identification and efficient filtration of different kinds of cutting fluid by one equipment. After pretreatment, the waste liquid enters through the inlet pipe of the filtration membrane group mechanism. The oil concentration detection sensor detects the concentration of the cutting oil in the liquid to determine the passing cutting oil or cutting liquid, realizes the type identification through the separation mechanism, and sends the waste liquid to the appropriate filtration module to complete the separation.

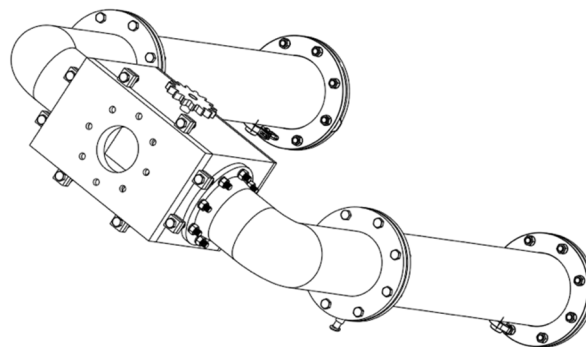

**Figure 2.** A bidirectional filter device

The schematic diagram of the structure of the membrane tube is shown in Figure Figure 4. Water based cutting liquid inlet, oil base cutting liquid outlet and water base cutting liquid outlet are distributed in the shape, the oil base cutting liquid outlet and water base cutting liquid outlet are set relatively, and the cutting liquid inlet is located at the top of the shape. The movable valve disc uses the rotary paddle as the working face, and the same side of the rotary paddle side of the rotary paddle as the working face of the oil base cutting fluid outlet and the oil base cutting fluid facing the outlet of the water base cutting liquid. When used as the oil-based cutting liquid working face, the cutting liquid inlet is connected with the oil-based cutting liquid outlet to form the circulation path of oil-based cutting liquid. When used as the water-based cutting liquid working face, the cutting liquid inlet is connected with the outlet of water-based cutting liquid to form the circulation path of water-based cutting liquid. Through the swing of the rotating paddle, it can easily realize the selection of the circulation path of oil base cutting fluid and water base cutting fluid. As shown in Figure 4, nine semiconductor inorganic film filter elements with size 6150 were filled.

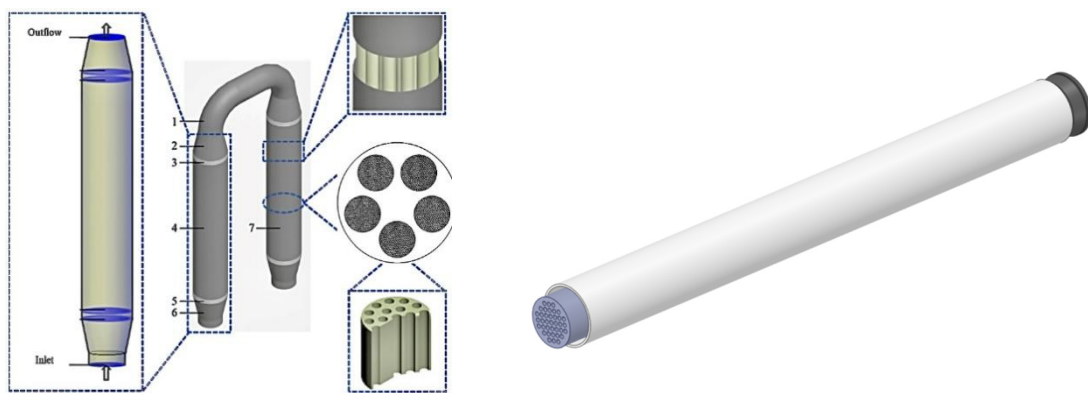

**Figure 3.** Structure diagram of ceramic inorganic membrane filter membrane tube filter module

The distinguishing principle of control compartment classification is to use the characteristics of high concentration of cutting oil in cutting oil and less impurity composition, while the concentration of cutting oil doped in cutting liquid is low. According to the oil concentration in the cutting fluid can refer to the data analysis, summarize the concentration content range, the sensor parameters are set to a fixed value, when the range of the detected concentration, the system determines the pipeline through the cutting oil, then the sensor sends electrical signal and passed to the drive motor, the motor drives the positive active gear rotation, and the active gear control to the specified position, to realize the sealing of the cutting oil pipe, and complete the cutting oil recovery. Conversely, if the detection concentration is below this threshold, the sensor controls the drive motor to reverse and the paddle also rotates to the opposite side and switch the pipe to the other side of the corresponding cutting fluid pipe.

### 4.3. Overall Structural Design

According to the technical requirements of the cutting liquid processor described above, the three-dimensional solid shape of the cutting liquid recycling filtration equipment is conducted. In the process of assembling the parts, the modification of some parts and the optimization of the structure, the overall model structure of the cutting liquid processing machine is finally determined.

The structure of the whole machine is shown in Figure 5. The working process of the cutting liquid filtration system is as follows: the cutting liquid wastewater is mixed evenly and poured into the sewage liquid pool, and the pumping pump is started. After the driving force of the pumping pump, the wastewater passes through the waste liquid pretreatment mechanism. During the filtration process, the internal filtrate will be filtered out from the filter tank tube body through the filter membrane surface, and the remaining filter liquid containing impurities will be sent away from the filter tank

along the membrane surface, which can be reasonably discharged or returned to the sewage liquid tank for circulation and filtration. In this project, a maintenance backwashing mechanism is added for the late cleaning and maintenance of the cutting fluid filtration device. When the circulation in the filtration tank is detected, stop the pumping pump to suspend the cutting fluid filtration process, and use the reverse washing pump to clean, the normal filtration function of the filtration membrane can be restored after the impurities and the tank internal hydraulic out of the filtration tank. The collected dirty liquid can be precipitated, the upper cutting liquid can be returned to the sewage pool to participate in filtration, and the lower precipitation can be cleaned to the centralized treatment of the slag collection box.

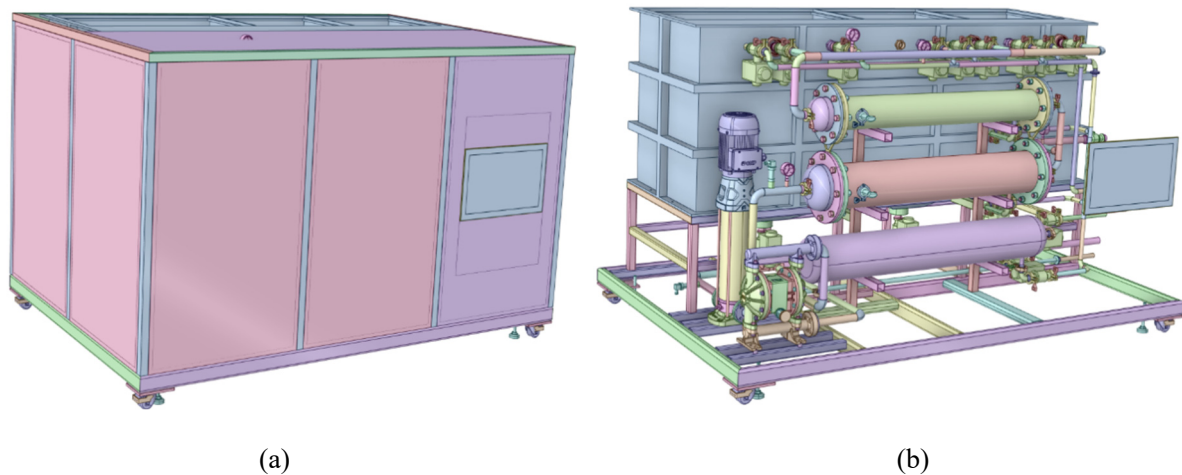

**Figure 4.** Model structure of the cutting fluid filtration device: (a) Appearance diagram: (b) Structure diagram

## 5. CONCLUSION

This paper puts forward five design principles of cutting liquid adaptive and controllable oil bidirectional separation and filtration system, models the circulating filtration equipment of cutting liquid university, and completes the modification of some parts and structure optimization, and the overall model structure of the cutting liquid processing machine is finally determined. The cutting liquid filter system of high strength and toughness steel based on semiconductor inorganic film is built.

## ACKNOWLEDGMENTS

Project Support: College Student Innovation and Entrepreneurship Project, Developed and designed a modular intelligent filtering and processing system for cutting fluid. Number 202410066001.

## REFERENCES

- [1] de Paiva Raphael Lima,de Souza Ruzzi Rodrigo,da Silva Rosemar Batista. An Approach to Reduce Thermal Damages on Grinding of Bearing Steel by Controlling Cutting Fluid Temperature[J]. Metals,2021,11(10).
- [2] Zhao Yaning, Wang Xiaoqiang. Analysis and exploration of the functional module of the centralized filtration system of cutting fluid [J]. New type of industrialization,2021,11(09): 155-157.DOI:10.19335/ j. cnki.2095-6649. 2021. 9.069.
- [3] Tzyy Jeng Yong, Yamuna Munusamy,Shi Jie Ding,Hanafi Ismail. Fabrication of a novel latex-based membrane for oily wastewater filtration: effect of degassing on the properties of membrane[J]. Iranian Polymer Journal,2021, 30 (10).

- [4] He Chuan, Shi Guanglin. Simulation analysis of cutting fluid temperature during drilling process [J]. Mechanical design and research, 2021,37(02):92-97+108. DOI:10.13952/j.cnki.jofmdr.2021.0062.
- [5] Liu Kun. Study on the design and optimization of the cutting fluid wastewater treatment device [D]. Qingdao University of Science and Technology, 2021.DOI:10.27264/d.cnki.gqdhc.2021.000012.
- [6] Abuhasel Khaled,Jeng Yong Tzyy,Munusamy Yamuna, Kchaou Mohamed,Alquraish Mohammed. Latex-Based Membrane for Oily Wastewater Filtration: Study on the Sulfur Concentration Effect[J]. Applied Sciences,2021, 11 (4).
- [7] Yi Gang. Preparation of separation membrane based on carbon nanotubes and MXene and electrical assistance [D]. Dalian University of Technology, 2020.DOI:10.26991/d.cnki.gdllu.2020.004078.
- [8] Xu Shaowei, Lu Ying, Song Tao, Liu Guicai, Zhang Shoubin, Xie Kang. Application of membrane technology in produced water from oil field [J]. Water purification technology,2020,39(11):101-105+151.DOI: 10.15890/j.cnki.jsjs. 2020.11.018.
- [9] Wang Yunping, Liu Yongcai, Zhao Jinpeng. Based on the automatic dust removal and filtration system of CNC machine tool [J]. Manufacturing technology and machine tools,2020(05):136-139. DOI:10.19287/j.cnki.1005-2402. 2020. 05.026.
- [10] Jianlin Liu, Xiaofei Zhu,Hongwei Zhang,Fuping Wu,Bigui Wei,Qing Chang. Superhydrophobic coating on quartz sand filter media for oily wastewater filtration[J]. Colloids and Surfaces A: Physicochemical and Engineering Aspects,2018,553.
- [11] Dai Xiaoyuan. Application of silicon carbide ceramic film in oil-water separation [D]. Wuhan University of Engineering, 2018.
- [12] Liu Yingkui, Huang Xiaobin. On-line monitoring and control of cutting fluid temperature in deep hole processing [J]. Tool technology,2017,51(12): 137-139.DOI:10.16567/j.cnki.1000-7008.2017.12.037.
- [13] Liu Weifeng. Research on the electrocondensation and purification process and device of cutting liquid in online circulation [D]. Dalian Jiaotong University,2017.
- [14] Lu Shun. Study on cutting liquid wastewater flocculation-UV / Fenton-adsorption combined treatment process and all-in-one machine design [D]. Shandong University of Science and Technology,2017.
- [15] Zhang Jiming. On-line monitoring of the deep hole processing cutting fluid system [D]. Beijing University Studies, 2016.
- [16] Cheng Liang. Design of workshop chip / liquid centralized treatment system for green manufacturing [D]. Dalian University of Technology,2015.
- [17] Frederic Güth, Pal Arki, Yvonne Joseph. Field-effect Based pH Sensors for Cutting Fluid Condition Monitoring[J]. Procedia Engineering,2015,120.
- [18] Fanuc Corporation; Researchers Submit Patent Application, "Machine Tool with Cutting Fluid Filtering Apparatus", for Approval[J]. Journal of Engineering,2014.
- [19] Li Hongrui. Study on the treatment of machining cutting liquid wastewater [D]. Harbin Institute of Technology,2013.
- [20] Zhao Xiaoqiang. Design of the cutting fluid PH monitor [J]. colliery engineering,2010,29(07):141-142.
- [21] Xiang Li. Research on the on-line circulation and purification equipment of metal cutting fluid [D]. Dalian Jiaotong University,2008.
- [22] Grigo Gunther. Cutting fluids filtration tasks and adjustable systems[J]. VDI Berichte,2008.