

# HVDC Transmission Simulation and Modeling

Wenhang Zhang, Jun Jin

School of Automation and Electrical Engineering, Dalian Jiaotong University, Dalian 116028, China

---

## ABSTRACT

HVDC transmission is a new transmission technology, but it is born with specialties, such as large transmission capacity, skillfully small transmission loss, long transmission distance, and relatively flexible and rapid transmission control. Therefore, HVDC power transmission technology develops rapidly in various countries around the world. Through the principle of HVDC transmission, analyzes the basic principle and hierarchy of HVDC system management, studied the basic components of management system, established the simulation model based on PSCAD / EMTDC model, and tested the principle and performance of HVDC system, DC transmission control trigger switch and transformer adapter. Finally, through simulation, the possible faults in DC transmission operation and the built converter trigger control and cutting filter model are simulated. It can conclude from the simulation waveform diagram that the fault of each device has very different influence on the system. Simulation results verify the correctness and rationality of the design.

## KEYWORDS

Simulation; Modeling of HVDC; Converter.

---

## 1. INTRODUCTION

There are three possible ways to model HVDC transmission systems with Matlab, which can be modeled according to the Matlab language and based on mathematical models HVDC system components (nonlinear calculus diagrams and its characteristic is that programming is simpler and faster than other languages (e.g., C, FOTRAIN), but relatively slow. Modeling and simulation based on SIMULINK toolbox is an elemental mathematical model in the form of transfer function, and the simulator is a model that simulates the entire system. The HVDC system can be modeled using the existing electrical components in the PSB repository, but the emergence of new technologies and the rapid development of new elements limit the scope of application of the original PSB library. With these features in mind, it is possible to use a combined model of Simulink and PSB to create a prototype of the HVDC power system directly from the existing electrical components in the PSB, as well as a Simulink model of the controller that we want to focus on, so that the main research can be highlighted quickly and intuitively.

## 2. HVDC TRANSMISSION ANALYSIS

The high-voltage DC enters the transformer's converter through a complex and changeable line, converts the high voltage through the inverter converter into current, and transfers the power through the transformer to the power system at the current frequency. The HVDC converter is divided into three parts, namely the rectifier side, the DC transmission side and the inverter side. An uninterruptible power supply means that the frequency flow generated by the power plant is enhanced to DC, which is delivered to the end through DC, and then the inverter switches to DC and inputs it

into the current DC system to complete the diversion conversion. The original of the converter is composed of an inverter and a rectifier, which is converted into open mode or closed mode inside the converter to realize AC and DC through open angle conversion. When the angle of the trigger exceeds 90 degrees, the switch is in an inverter state and is converted into alternating current by high voltage. The angle of the trigger is less than the right angle, and the inverter is in a normal state.

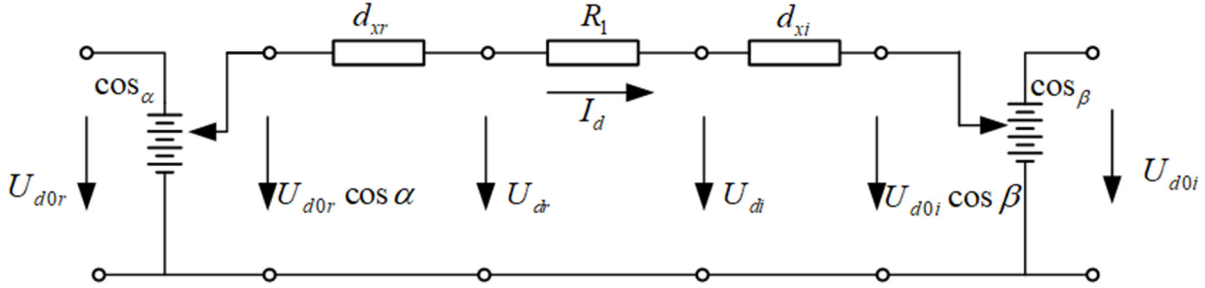

**Figure 1.** Schematic diagram of HVDC transmission

In Figure 1, the r and i in the variable indices below correspond to the ratio commutation voltage drop of the exchange voltage between the rectifier and the inverter, and the voltage on the rectifier side and the corresponding voltage of the DC inverter, respectively.  $\alpha$  and  $\beta$  are the resistors of the DC transmission line;  $I_d$  is the current of the DC transmission line.

The DC current from the rectifier side to the inverter side is equal to:

$$I_d = \frac{U_{dor} \cos \alpha - U_{doi} \cos \beta}{d_{xr} + R_1 + d_{xi}} \quad (1)$$

The power of the rectifier termination is:

$$P_{dr} = V_{dr} I_d \quad (2)$$

The terminal power of the inverter is:

$$P_{di} = V_{di} I_d = P_{dr} - R_L I_d^2 \quad (3)$$

$$\begin{aligned} \cos \varphi &\approx 0.5 [\cos \alpha + \cos(\alpha + \mu)] \\ &\approx 0.5 [\cos \gamma + \cos(\gamma + \mu)] \end{aligned} \quad (4)$$

Therefore, in order to obtain a high power factor, the rate angle and reflection angle of the rectifier must be as small as possible.

### 3. MATHEMATICAL MODEL OF DC TRANSMISSION

#### 3.1. Steady-state Model of the Inverter

The quasi-steady-state DC system model is also a widely used computational model. In this model, the interaction of the multi-bridge transducer shoulders can be ignored and the limitation of the transducer angle can be incorporated into the DC control. The characteristics of the transducer are still the average value of DC and the RMS of the basic elements of AC.

The steady-state equation for the inverter is summarized as follows:

$$V_{do} = \frac{3\sqrt{2}}{\pi} BTE_{ac} \quad (5)$$

$$V_d = V_{do} \cos \delta - \frac{3}{\pi} X_c I_d B \quad (6)$$

Or something like this:

$$V_d = V_{do} \cos \gamma - \frac{3}{\pi} X_c I_d B \quad (7)$$

$$\delta \approx \cos^{-1} \left( \frac{V_d}{V_{do}} \right) \quad (8)$$

$$P = V_d I_d = P_{ac} \quad (9)$$

$$Q = P \tan \varphi \quad (10)$$

In the transition state of the engine, it is relatively simple to simulate with a DC inverter, and many factors are correspondingly not taken into account, and the DC system is often used as a model for the conduction system, which is widely used to calculate the actual power transmitted by the line, and is used to study the electrical energy consumed by the input and output of the computer. From the feedback data of the DC system in practice, it can be seen that the signal generation mode is usually modulated according to the strength of the converter. A specific time delay is used to eliminate the distinction between DC voltage, DC voltage, and corresponding value. Use simpler inertia and oscillation spans to model the dynamic behavior of current regulators and DC lines. This simplified model is practically unable to distinguish between the characteristics of a high frequency response. The high computational efficiency of this simplified model allows it to be widely used to analyze stability without the need for a high-precision response to a constant current. But if you want to analyze the DC mechanism and its effects on the AC system more precisely, you need to introduce a quasi-steady state model.

### 3.2. Model of DC Network

The DC network is composed of three parts, which are the smooth reactor, the DC transducer and the wires of the transmission line. Among them, a smooth DC reactor filter can be expressed using linear parametric equations in mathematics, and there are specific formulas that make the data obtained in practice more authoritative. When the high-frequency features are invariant in the parametric equations, the network shown in the figure is a circuit that describes the equivalent algebraic equations with respect to the t-type. For example, suppose there is a unipolar linear equation and each substation contains 6 transducers that can pulse current, ignoring the changes in other data caused by the change of the DC transducer, and the smoothing reactor numbers at both ends of the circuit do not fluctuate too much. and the DC network are shown in Figure 2.

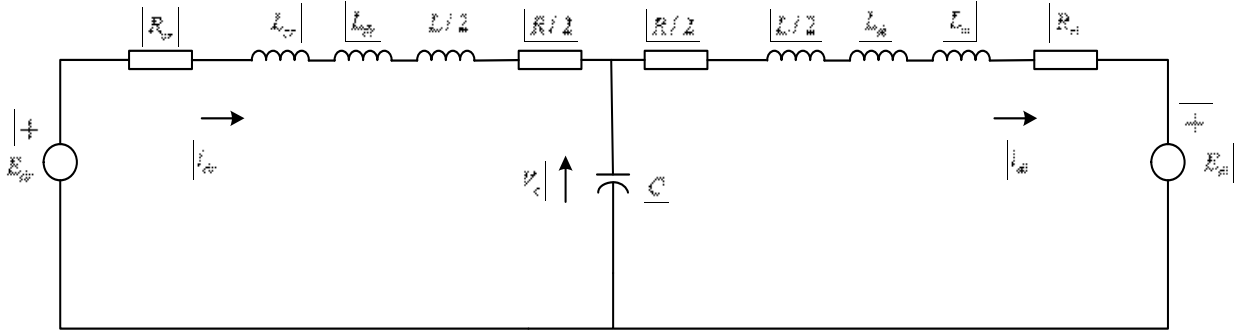

**Figure 2.** DC network diagram

The equation of state of the network in Figure 2 is:

$$di_{dr} / dt = -R_{tr} / L_{tr} i_{dr} + (E_{dr} - v_c) / L_{tr} \quad (11)$$

$$di_{di} / dt = -(R_{ti} / L_{ti}) i_{di} + (v_c - E_{di}) / L_{ti} \quad (12)$$

$$dv_c / dt = 1 / C (i_{dr} - i_{di}) \quad (13)$$

In the formula

$$L_{tr} = L_{cr} + L_{dr} + L / 2 \quad (14)$$

$$L_{ti} = L_{ci} + L_{di} + L / 2 \quad (15)$$

$$R_{tr} = R_{cr} + R / 2 \quad (16)$$

$$R_{ti} = R_{ci} + R / 2 \quad (17)$$

Generally speaking, the formula for the equation of state of a DC network is:

$$X_{dc} = A_{dc} X_{dc} + B u_{dc} \quad (18)$$

$$y_{dc} = C X_{dc} \quad (19)$$

#### 4. MODELING OF THE PRIMARY SYSTEM OF HVDC TRANSMISSION

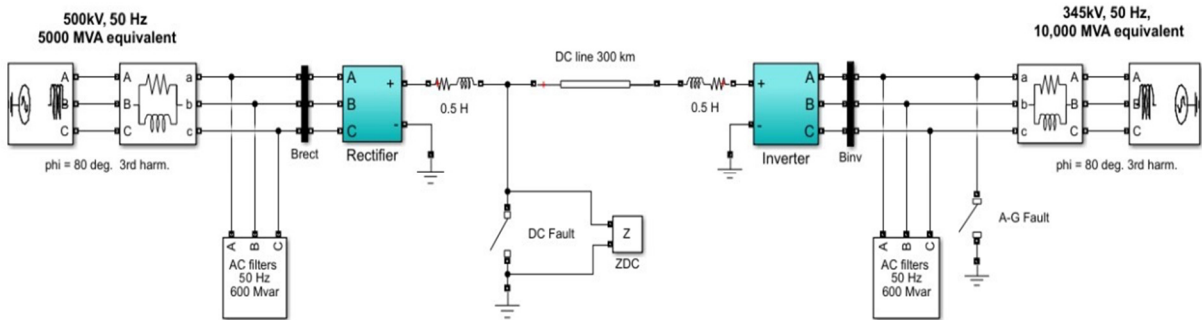

**Figure 3.** Simulation model of the primary HVDC transmission system

Electrical equipment such as converter transformers, rectifiers, inverters, and DC transmission lines together constitute a primary system for HVDC transmission, enabling it to carry out AC/DC conversion and power transmission. The structure of the actual HVDC transmission system is very

complex, involving many fields and huge scale, so the simulation model cannot build all the electrical equipment that makes up the primary system. Based on the above factors and increasing the speed of simulation calculation as much as possible, a detailed simulation model is established for the key research objects under the premise of achieving the expected simulation effect, and some minor factors are briefly modeled.

Based on the principle of HVDC transmission and the composition of the actual HVDC transmission system, the primary system simulation model is built by SIMULINK software, as shown in Figure 3. The converter transformer and rectifier complete AC/DC conversion on the rectifier side, and the DC obtained by rectification is then filtered by the flat-wave reactor and transmitted to the DC transmission line. The DC power is transmitted to the other end of the DC transmission line, and then it is filtered by a flat-wave reactor, and then inverted to realize the conversion from DC to AC, so as to complete the process of high-voltage DC transmission.

Circuit breakers on the DC line and on the AC line on the inverter side can be used to simulate single-phase ground faults on the DC side and AC side lines. The AC voltage at the sending end is 500kV with a capacity of 5000MVA, and the AC filter is filtered and reactive power is compensated. The three-phase alternating current after passing through the converter transformer is rectified by a rectifier. The rectified DC power is transmitted through a 300km DC transmission line through a flat-wave reactor to suppress the ripples, and then through the flat-wave reactor to suppress the ripples, and then inverted by an inverter. At this time, the direct current becomes alternating current, and the voltage becomes 345kV after passing through the converter transformer, and the inverter AC side obtains a more ideal three-phase alternating current after an AC filter, and then passes it to the receiving end for the user to use. This is the whole process of simulating a HVDC transmission system.

## 5. SIMULATION ANALYSIS OF HVDC TRANSMISSION SYSTEM

In this transmission system simulation, the DC voltage reference value is set to 500 kV and the DC current reference value is 2 kA, and the original standard voltage and current are used throughout the simulation. In the simulation process, the whole system is adjusted to work in a stable state, and then the reference voltage and current are operated, as shown in Table 1.

**Table 1.** System control parameters change over time

number	moment	action
1	0s	The voltage reference value is 1pu
2	0.02s	The converter is turned on, the current rises, and the minimum steady-state current is referenced
3	0.4s	The current is increased to the set value by the specified slope
4	0.7s	The reference current drops by 0.2pu
5	0.8s	The reference current is restored to the set value
6	1.0s	The reference voltage drops from 1 pu to 0.9 pu
7	1.1s	The reference voltage is restored to 1pu
8	1.4s	The converter is turned off
9	1.6s	Force the trigger delay angle to be set to the specified value
10	1.7s	Turn off the converter

Before starting the simulation, it is necessary to design the parameters of each subsystem, and when the data entry is completed, it can enter the simulation. Looking at the oscilloscope that detects the rectifier and inverter, as shown in Figure 4, you can see the waveform of the voltage and current.

As shown in Figure 4-(a), the relevant waveform obtained on the rectifier side is represented by the DC line voltage represented by the reference value, the DC line current, its actual reference current is represented by the reference value, and the first trigger delay angle is represented by the angle.

As shown in Figure 4-(b), the relevant waveform obtained in the inverter section represents the DC sideline voltage and the reference voltage as standard values, and from top to bottom, the standard values represented by the DC sideline current and the actual reference current. The angle represents the first trigger delay angle, the minimum arc extinguishing angle, the current state of the inverter, and the arc extinguishing angle reference value

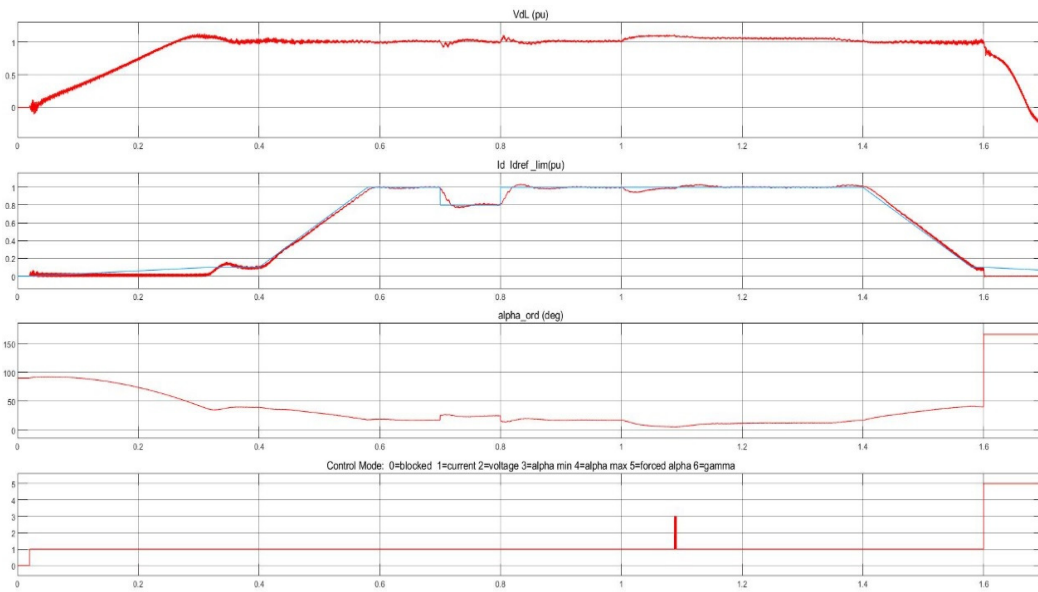

(a) Correlation waveform obtained on the rectifier side

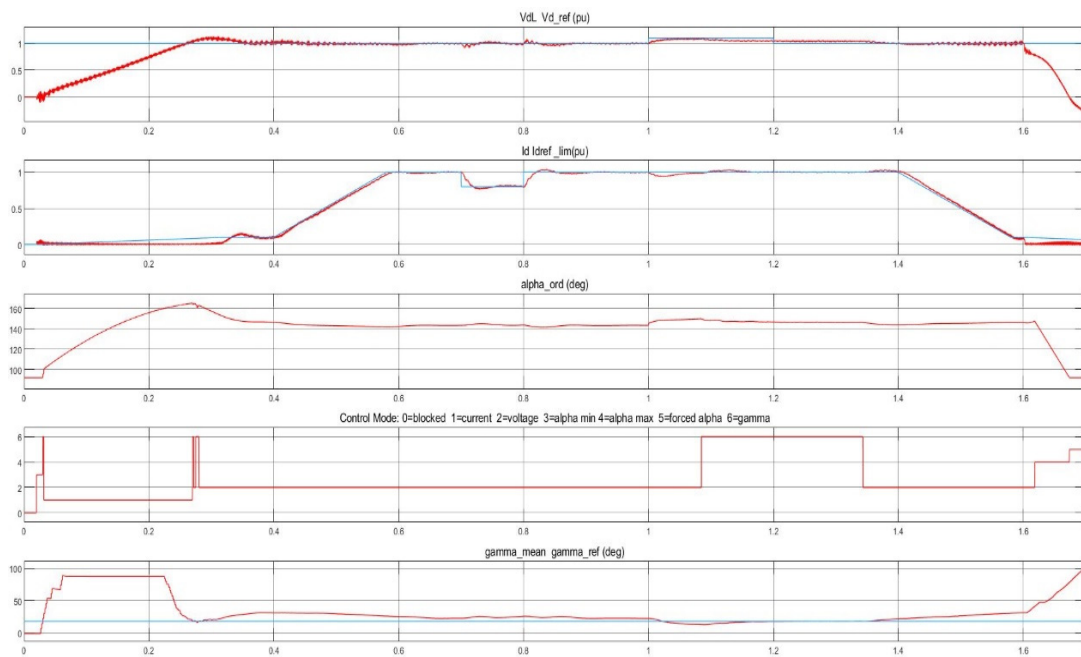

(b) Correlation waveforms obtained from the inverter side

**Figure 4.** Simulation of start-stop and step response of HVDC system

By comparing Table 1 with Figure 4, we can see the approximate process: at 0.02s, the thyristors in the rectifier and inverter are turned on, and it can be clearly seen from the figure that the current begins to rise, and when the current rises to 0.1pu and the reference value of the minimum steady state of the system, it takes 0.3s, the voltage of the DC line reaches 1.0pu, and the inverter and rectifier reach the state of current control. When it reaches 0.4s, the reference current reaches 1.0pu (2kA) from 0.1pu, and at 0.58s the DC current has stabilized, the rectifier is controlled by the current, the inverter is controlled by the voltage, and the voltage on the DC side is kept at 1pu (500kV). When the system is stable, it can be observed that the trigger delay angle of the rectifier is about  $16.5^\circ$ , while the trigger delay angle of the inverter is about  $143^\circ$ . The inverter subsystem measures the arc extinguishing angle of the thyristors in two six-pulse bridges with a reference value of  $12^\circ$ , and the minimum arc extinguishing angle is approximately  $22^\circ$  at steady state of the system. At 1.0s, the reference voltage is offset by 0.1pu, and it can be restored to the set value after 0.1s. However, the arc quenching angle of the inverter is still larger than the reference value. L.6s, the trigger delay angle on the rectifier side will be forcibly set to  $166^\circ$ , and the trigger delay angle on the inverter side will be  $92^\circ$ , and the DC circuit will be discharged. At 1.7s, both the rectifier and the inverter are turned off, and the state of the controller is 0.

The circuit breaker closes at 0.7s and disconnects at 0.85s. After setting the relevant data, the system is simulated, and the fault diagram after simulation is shown in Figure

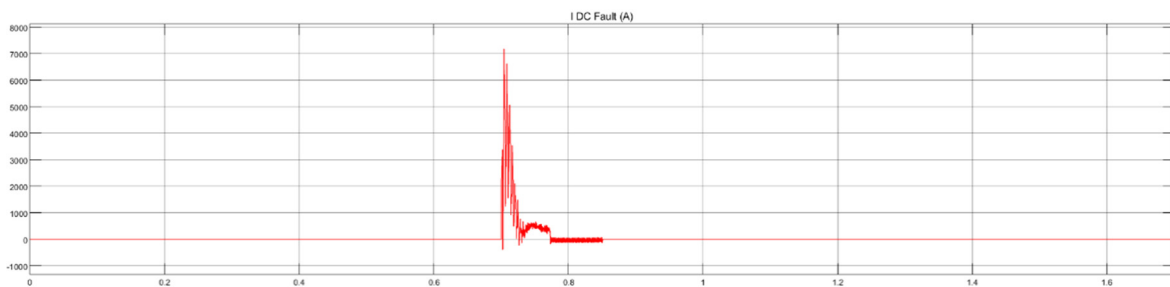

**Figure 5.** Waveform on the fault side of a DC line fault

At 0.7s, the DC ground fault is connected in the line, and the current on the DC side rises to around 2.1pu, and the voltage on the DC side decreases to zero in an instant.

So there is current flowing on the DC side, and the line may also fail. When the DC voltage changes around 0.78s, the DC fault protection subsystem can detect it and respond accordingly. The rectifier trigger delay angle is forced to be set to the maximum, and the rectifier is in the inverter state. When the DC side line voltage becomes negative, the energy stored in the DC line is transmitted to the AC system, causing the fault current to go out at a very fast rate at the zero crossing. When 0.83s, the forced value of the trigger delay angle is removed, and the rated DC voltage returns to normal after 0.4s, and the current returns to normal after 0.3s.

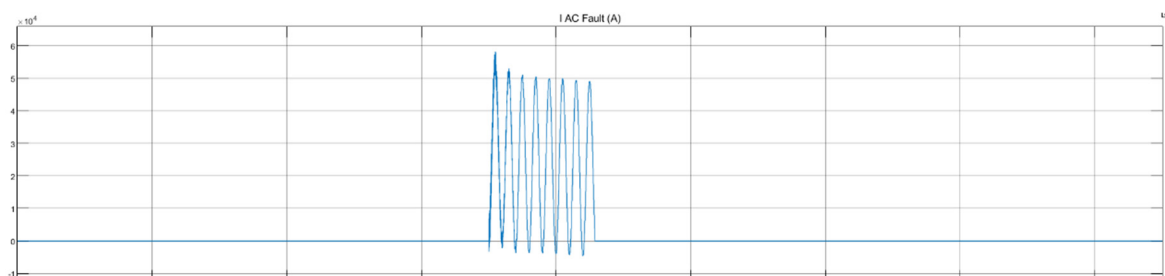

**Figure 6.** shows the current-dependent waveform at the fault point of a short-to-ground circuit.

## 6. SUMMARY

Through the PSB module of Matlab and Simulink, SimPowerSystems and other toolboxes, you can simulate, model and analyze HVDC transmission, and analyze faults, and display each data in the form of curves, which can clearly and intuitively analyze the system.

In the design, several typical faults generated during the operation of HVDC transmission are simulated and analyzed by MATLAB/Simulink software. When doing the start-stop step simulation, you can clearly see the waveform change of AC to DC and the current jump of the system when receiving the step signal. In order to save space, the most representative faults in this paper are simulated and analyzed in MATLAB/Simulink, and the relevant waveforms are obtained as shown in the above figures. From the simulation waveform diagram, it can be concluded that the failure of each equipment has its own characteristics and the degree of impact on the system is also very different, and the failure can be determined by analyzing the fault. For example, the frequency of single-relative short-circuit on the inverter side is high, but the harm caused to the transmission system is not as serious as the fault when the three-relative short-circuit is serious, and the surge value of the voltage during the three-relative short-circuit is significantly higher than that of the single-relative short-circuit (single-phase surge to 1.5pu, three-phase surge to 2pu), such a large current is likely to cause damage to equipment and casualties, which is worthy of our attention

## REFERENCES

- [1] Theory and analysis of dynamic power system[M]. Tsinghua University Press, Ni Yixin. 2002.
- [2] Research on Modeling Analysis and Damping Control of DC Power Grid[J]. LI Yunfeng, TANG Guangfu, WU Yanan, YANG Jie. Proceedings of the CSEE. 2017.
- [3] Huang Zhonglin. MATLAB calculation and simulation of control system[M]. Beijing: National Defense Industry Press. 2001.
- [4] Research on Suppression Method for Continuous Commutation Failure of Harmonic-Induced HVDC Transmission [J]. ZHANG Guohui, JING Liuming, WANG Bin, LIU Meng, DONG Xinzhou. Power System Protection and Control. 2020(05).
- [5] Coupling Effect and Fault Pole Selection Scheme of HVDC Transmission Line[J]. Chu Xu, Wang Liang, Wang Huawei, Song Guobing. Electric power automation equipment. 2017(04).
- [6] New principle of current differential protection for HVDC transmission lines[J]. Gao Shuping, Sonam Jiale, Song Guobing, Zhang Jianxing, Hou Zhuo. Power System Automation. 2010(17).
- [7] Research on conductor selection of HVDC transmission line[D]. Ren Xiaolong. North China Electric Power University. 2014.
- [8] Auxiliary frequency control strategy for DC transmission suitable for wind power access[J]. ZOU Peng, WANG Yuhong, LI Xingyuan, GONG Hong. Proceedings of the CSEE. 2016.
- [9] Multi-terminal DC transmission and DC power grid technology[J]. Tang Guangfu, Luo Xiang, Wei Xiaoguang. Proceedings of the CSEE. 2013 (10).