

An Innovative IoT-Based Intelligent Control System for Agricultural Greenhouses

Xiaolei Zhong¹, Rui Qiao^{2, 3, *}, Xin Wang^{4, 5}

¹ Dianchi College, Kunming 650228, China

² School of computer science and technology, Wuhan University of Science and Technology, Wuhan 430065, China

³ Hubei Province Key Laboratory of Intelligent Information Processing and Real-time Industrial System, Wuhan 430065, China

⁴ Yunnan College of Business Management, Anning 650301, China

⁵ Huazhong University of Science and Technology, Wuhan 430074, China

* Corresponding Author: Rui Qiao

ABSTRACT

As the material living standards of residents rapidly improve, the demand for fruits and vegetables continues to rise. Agricultural greenhouses, as a critical means of increasing fruit and vegetable yields, require effective control of temperature, humidity, and light intensity to ensure rapid crop growth. Traditional manual monitoring and control methods are inefficient and labor-intensive. Against the backdrop of rapid developments in electronic technology, this paper innovatively designs a greenhouse IoT intelligent control system based on a microcontroller, achieving real-time monitoring and automated control of greenhouse environment parameters. The innovations of this system are evident in several aspects: Firstly, it employs an STM32 microcontroller as the main control chip, integrating YL-69 soil moisture sensors, GL5506 photodiodes, and DS18B20 temperature sensors to achieve high-precision detection of soil moisture, light intensity, and temperature. Secondly, an LCD1602 display is used to timely showcase real-time environmental parameters, and alarm thresholds can be set via buttons. If these thresholds are exceeded, a buzzer sounds an alarm. Concurrently, the system utilizes water pumps and supplementary LED lights to intelligently adjust humidity and light intensity within the greenhouse. Most importantly, by incorporating the ESP8266 module, the system achieves remote data transmission, allowing users to view real-time environmental parameters via a mobile app and set thresholds and control operations. This greenhouse IoT intelligent control system not only features alarm functions for exceeded environmental parameters but also enables automatic adjustment through intelligent devices and supports remote control, greatly enhancing operational convenience and system practicality. Overall, this system innovatively integrates various sensing technologies and IoT communication, providing an efficient and intelligent solution for the modern management of agricultural greenhouses. It exhibits broad market prospects and holds significant importance for advancing agricultural modernization.

KEYWORDS

STM32; Greenhouse; Temperature and Humidity Control; WiFi Communication; Internet of Things.

1. INTRODUCTION

In recent years, with the continuous improvement of residents' material living standards, fruits and vegetables have increasingly become an essential part of daily diets [3]. Agricultural greenhouses, as

an advanced production method, significantly enhance the yield and quality of fruits and vegetables by providing a controlled growing environment. However, traditional manual monitoring and control of greenhouse environmental parameters have several shortcomings, particularly in terms of efficiency and human resource investment. This greatly limits the production efficiency and economic benefits of greenhouses. [1] [2]

With the rapid development of electronic technology and the Internet of Things (IoT), automated and intelligent greenhouse environmental control systems have emerged[4]. By utilizing modern sensor technology, intelligent control algorithms, and wireless communication technologies, it is possible to achieve real-time monitoring and precise control of critical environmental parameters such as temperature, humidity, and light intensity within the greenhouse. This ensures that crops grow under optimal conditions, maximizing yield and quality.

This paper aims to design and implement a microcontroller-based IoT intelligent control system for greenhouses, providing comprehensive real-time monitoring and automatic adjustment of the greenhouse environment. The system employs STM32 as the main control chip, in combination with YL-69 soil moisture sensors, GL5506 photodiodes, and DS18B20 temperature sensors to achieve high-precision detection of soil moisture, light intensity, and temperature. To visualize information and enable user interaction, the system integrates an LCD1602 display to show real-time environmental parameters. Users can set alarm thresholds via buttons. When the environmental parameters exceed the set thresholds, the system triggers an alarm signal and activates adjustment devices such as water pumps and supplementary LED lights to automatically modify environmental conditions.

Furthermore, the system utilizes the ESP8266 module to enable remote data transmission. Users can view the internal environmental parameters of the greenhouse in real-time through a mobile app and perform remote control and threshold settings, greatly enhancing the system's operational convenience and practicality.

By incorporating the above technological solutions, the designed IoT intelligent control system for greenhouses not only enhances the level of agricultural production intelligence but also demonstrates the development prospects of modern agriculture. It provides innovative technical support for advancing agricultural modernization.

2. SYSTEM DESIGN

The IoT-based intelligent greenhouse control system consists of four primary components: sensor module, control module, user interface module, and remote communication module. The functional block diagram is shown below in Figure 1.

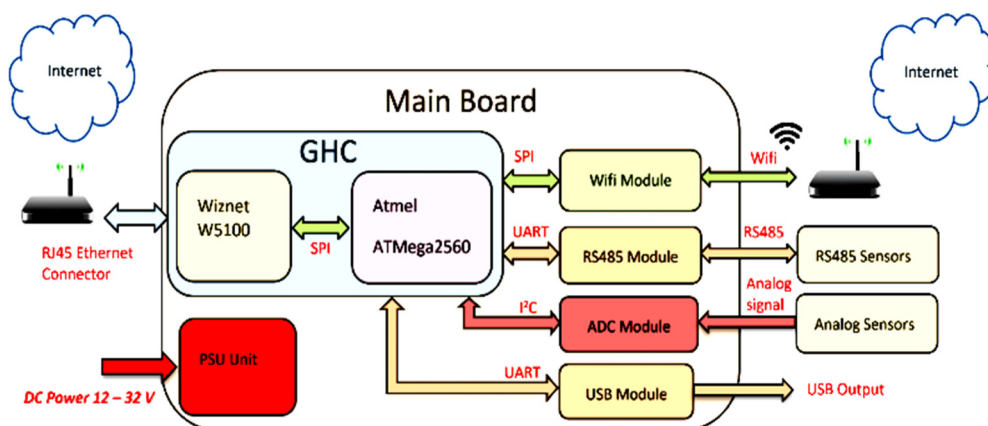

Figure 1. The functional block diagram

2.1. Sensor Module

The sensor module is responsible for collecting and monitoring real-time environmental data within the greenhouse. In this design, we employ the following sensors:

1. YL-69 Soil Moisture Sensor: This sensor measures the moisture content of the soil, ensuring that the plants receive an optimal amount of water.
2. GL5506 Photodiode: This sensor detects the level of light intensity inside the greenhouse, which is essential for photosynthesis and plant growth.
3. DS18B20 Temperature Sensor: This sensor monitors the temperature within the greenhouse, as it significantly influences the germination, growth, and overall health of the plants.

2.2. Control Module

The control module is the core of the system, processing the data obtained from the sensor module and making decisions based on predefined algorithms and user-set thresholds [5]. The STM32 microcontroller is utilized as the main control chip in this design due to its high performance, low power consumption, and extensive range of peripherals.

Based on the environmental data, the control module can activate or deactivate various adjustment devices to maintain the optimal conditions for plant growth. These devices include:

1. Water Pump: This device is activated when the soil moisture level falls below the user-set threshold, ensuring that the plants are adequately watered.
2. Supplementary LED Lights: These lights are turned on when the light intensity inside the greenhouse is insufficient, providing the necessary illumination for photosynthesis.
3. Heating/Cooling System: This system is activated when the temperature inside the greenhouse deviates from the optimal range, maintaining a suitable environment for the plants.

2.3. User Interface Module

The user interface module facilitates user interaction and visualization of the system's data. In this design, an LCD1602 display is used to showcase real-time environmental parameters, such as soil moisture, light intensity, and temperature. Additionally, buttons are integrated into the system, allowing users to set alarm thresholds and manually override the system's automatic adjustments if necessary.

2.4. Remote Communication Module

The remote communication module enables users to access the system's data and perform remote control via a mobile app [6]. In this design, the ESP8266 module is employed to establish a wireless connection between the greenhouse control system and the user's mobile device. The mobile app is designed to display real-time environmental data, as well as provide options for users to adjust the alarm thresholds and control the adjustment devices remotely.

By integrating these four components, the IoT-based intelligent greenhouse control system offers a comprehensive solution for monitoring and maintaining the optimal environmental conditions for plant growth, ultimately contributing to the advancement of agricultural modernization.

3. SYSTEM IMPLEMENTATION

The implementation of the IoT-based intelligent greenhouse control system involves the integration of both hardware and software components.

3.1. Hardware Implementation

The hardware components of the system include the STM32 microcontroller, YL-69 soil moisture sensor, GL5506 photodiode, DS18B20 temperature sensor, LCD1602 display, buttons, water pump, supplementary LED lights, heating/cooling system, and ESP8266 module. The connections between these components are as follows:

1. STM32 Microcontroller: The STM32 serves as the central processing unit for the system. It is connected to the sensors, LCD display, buttons, and ESP8266 module via their respective data and power lines.
2. Sensors: The YL-69, GL5506, and DS18B20 sensors are connected to the STM32 microcontroller's analog-to-digital converter (ADC) inputs for data acquisition. The sensors are also connected to the system's power supply.
3. LCD1602 Display: The LCD display is connected to the STM32 microcontroller's digital inputs/outputs for data and control signals. The display's power supply is also connected to the system's power source.
4. Buttons: The buttons are connected to the STM32 microcontroller's digital inputs for user interaction and threshold setting.
5. Adjustment Devices: The water pump, supplementary LED lights, and heating/cooling system are connected to the STM32 microcontroller's digital outputs via relay modules. This allows the microcontroller to control the devices' on/off states.
6. ESP8266 Module: The ESP8266 module is connected to the STM32 microcontroller's UART (Universal Asynchronous Receiver/Transmitter) interface for wireless data transmission and remote control. The hardware connection diagram is shown below in Figure 2.

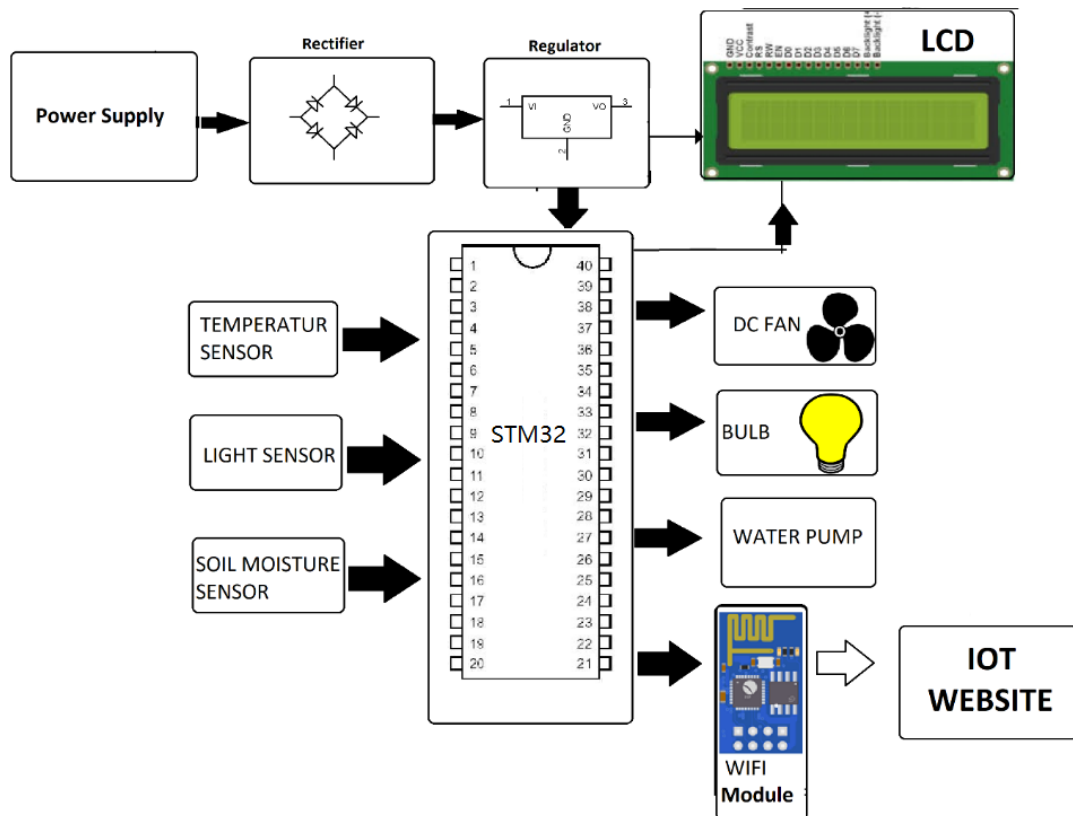

Figure 2. The hardware connection diagram

3.2. Software Implementation

The software components of the system include the microcontroller firmware, mobile app, and cloud server.

1. Microcontroller Firmware: The firmware for the STM32 microcontroller is developed using the Keil μ Vision IDE and the STM32CubeMX toolchain. The firmware is responsible for data acquisition from the sensors, data processing and decision-making, LCD display updates, user interaction via buttons, and communication with the ESP8266 module.

2. Mobile App: The mobile app is designed and developed using a cross-platform mobile app development framework, such as React Native or Flutter. The app is responsible for displaying real-time environmental data, receiving user inputs for threshold setting and remote control, and communicating with the cloud server.

3. Cloud Server: The cloud server is implemented using a cloud computing platform, such as Amazon Web Services (AWS) or Google Cloud Platform (GCP). The server is responsible for storing and managing the system's data, as well as facilitating communication between the mobile app and the microcontroller. The functionality verification of the water pump automatic irrigation circuit in the greenhouse IoT intelligent control system is shown below in Figure 3. When the watering conditions are met, the water pump starts and simulates irrigation.



Figure 3. IoT intelligent control system

4. CONCLUSION

The IoT-based intelligent greenhouse control system provides a comprehensive solution for monitoring and maintaining optimal environmental conditions for plant growth. By integrating advanced sensor technology, intelligent control algorithms, and wireless communication technologies, the system ensures that crops grow under the best possible conditions, maximizing yield and quality. The implementation of this system not only enhances the level of agricultural production intelligence but also demonstrates the development prospects of modern agriculture, providing innovative technical support for advancing agricultural modernization.

ACKNOWLEDGMENTS

This work was supported by the National Nature Science Foundation of China (grant no. 61461053, 61461054).

REFERENCES

- [1] Y.H. Xi, N. Zhang, Q.R. Zhang. IoT-Based Intelligent Greenhouse Control System for Smart Agriculture, *Computer Knowledge and Technology*, Vol. 20 (2024) No. 3, p.8-10. DOI: 10.14004/j.cnki.ckt.2024.0156.
- [2] L.G. Teng. Research on IoT-Based Intelligent Control System for Agricultural Greenhouses, *Smart Agriculture Journal*, Vol. 3 (2023) No. 23, p.1-5. DOI: 10.20028/j.zhnydk.2023.23.001.
- [3] G.L. Gao, C.P. Li, S.S. Fu, et al. Design of IoT-Based Intelligent Greenhouse Control System, *Shandong Industrial Technology*, (2023) No. 2, p.71-77. DOI: 10.16640/j.cnki.37-1222/t.2023.02.012.
- [4] T.G. Lu, H.X. Zhang, C. Tang, et al. Research on Intelligent Control System for Solar Greenhouse Based on Agricultural IoT, *Modern Agricultural Science and Technology*, (2022) No. 2, p.147-151.
- [5] Q. Zuo. Design and Implementation of Embedded Greenhouse Environmental Intelligent Monitoring System, *Yunnan Chemical Technology*, Vol. 48 (2021) No. 1, p.110-112.
- [6] G.R. Zhong, S.H. Wu, Y.D. Bao, et al. IoT-Based Intelligent Greenhouse Control System, *Electronic Technology & Software Engineering*, (2019) No. 8, p.238-245.