

Optimization of Outlet Flow Pulsation in Axial Piston Pump

Rongqiu Shi *, Zegang Sun

College of Mechanical Engineering, Sichuan University of Science & Engineering, University, Yibin, China

* Corresponding Author: Rongqiu Shi

ABSTRACT

Axial piston pumps are commonly used as key equipment in the petroleum industry to transport crude oil and petroleum products. Outlet flow pulsation refers to the periodic change of pump outlet flow in a certain period of time, which will have a certain impact on the petroleum industry. The export flow pulsation will affect the transportation stability of petroleum products, and the export flow pulsation will also affect the quality of petroleum products. The transition zone of the high and low pressure conversion of the distribution disc throttle groove during the operation of the axial piston pump will affect the flow backflow at its outlet, which further affects the flow pulsation. Therefore, the key parameters of different distribution trays are studied. The influence of the key parameters of the V-groove and the U-groove on the flow pulsation of the distribution plate was studied, and the U-shaped groove was optimized, and a V-shaped opening was added at the end of the U-shaped groove to reduce the flow pulsation.

KEYWORDS

Axial Piston Pump; Throttling Groove; Ripple Egress Flow; AMESim Simulation.

1. INTRODUCTION

In hydraulic systems, hydraulic pumps are often considered the main source of noise. [1] Plunger pumps are widely used in industrial hydraulics and traveling machinery hydraulics due to advantages such as high power density and rich forms. [2] Plunger pump noise can usually be divided into two categories: fluid noise and mechanical noise. Fluid noise is the focus of current research, while mechanical noise is the noise excited by the movement of mechanical parts in the pump or the interaction of forces and moments cyclical changes in vibration. Fluid noise in the hydraulic system is mainly due to flow pulsation and system impedance interaction generated by the pressure pulsation. The pressure pulsation of the piston pump is mainly due to its mode of motion generated by the motion flow and its own structure caused by the dynamic flow in the impedance of the formation. [3] Plunger pump in the suction and discharge process due to the pressure impact and generate excitation force, this will cause the structural vibration of the pump components, which leads to the pump casing and related components of the mechanical vibration, air noise. [4] Fluid noise and structural noise will exacerbate the air noise. Vibration leads to many adverse effects such as overheating, damage and noise. [5] Junior Li [6] established a mathematical model and AMESim simulation model of oil pressure change in plunger cavity considering the effect of friction vice leakage, and investigated the effect of different flow distribution structures on the distribution impact of plunger pump. Li Zhipeng [7] proposed a new type of flow distribution disk structure using an additional oil channel to pre-drain the high-pressure oil in the non-dead point transition zone to the upper dead point transition zone, which not only reduces the flow pulsation and pressure shock, but also the high-pressure fluid in the transition zone is reutilized to improve the energy efficiency of the hydraulic pump.

Vibration noise in hydraulic systems can have an impact on verbal communication at the work site, the physical and mental health of staff, and the reliability and safety of the system. In current production or use of hydraulic piston pumps, poorly designed distributor disk trapped oil areas may lead to pressure shocks and backed-up flow, which in turn generates vibration noise and becomes the main source of vibration noise in the pump. [4] Hydraulic pumps are usually considered as the main source of noise in hydraulic systems. Therefore, analyzing and studying the characteristics of hydraulic pumps to reduce their noise level is crucial for the noise control of the whole hydraulic system. Flow pulsation is the root cause of fluid noise in piston pumps. [8] Therefore, reducing the noise during the operation of axial piston pumps is an important research direction.

2. THE STRUCTURE OF THE DISTRIBUTOR AND THE PROCESS OF ITS ACTION

As shown in Figure (refer with: Fig. 1), the drive shaft 1 drives the connecting rod 2 to deflect, the connecting rod 2 connects to the inner bore wall of the plunger 3, and at the same time drives the cylinder 4 to rotate, and the plunger 3 completes one expansion and contraction in one rotation cycle. The plunger 3 connects with the suction chamber waist-shaped hole a to elongate to complete the suction, and connects with the discharge chamber waist-shaped hole b to compress to complete the oil discharge [9]. The radial force on the plunger 3 in the working process is small, and the inclination angle between the axis of the center shaft 6 and the axis of the transmission 1 axis can reach 40° , but its volume is large, and the adjustment of the output flow rate requires the adjustment of the angle between the cylinder body and the transmission shaft, and the motion inertia is large, and the response is slow [10].

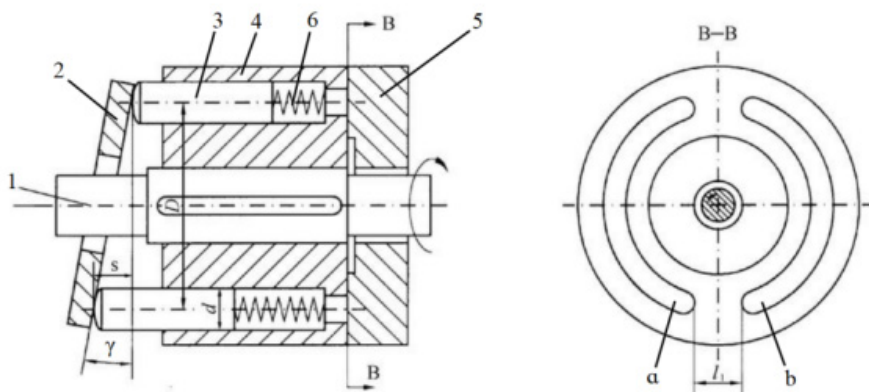

1-drive shaft; 2-swash plate; 3-plunger; 4-cylinder; 5-mating disk; 6-spring

Figure 1. Structural Diagram of Swash Plate Axial Piston Pump

3. AXIAL PISTON PUMP SIMULATION MODEL

AMESim is a platform for modeling and simulation of complex systems in multidisciplinary fields based on the theory of bond graphs, which contains a wealth of application libraries, such as mechanical libraries, signal control libraries, hydraulic libraries, motor and drive libraries, and so on. [11] According to the analysis of the working principle of the axial piston pump above, the axial piston pump can be divided into two parts, one part is the axial piston pump, and the other part is the swashplate moment AEMSim simulation model. Build a single plunger on the swash plate rotation on 360° on the case of normal operation, build nine plungers of the plunger pump, because they before the existence of 90° phase angle, and then after that build the remaining eight plungers. As shown in Figure (refer with: Fig. 2), build the AMESim-based axial piston pump simulation model, which consists of structural elements such as flow distribution disk, swash plate plunger connector

element and other structural elements. and other parameters of the AMESim model are shown in Table (refer with: Table 1).

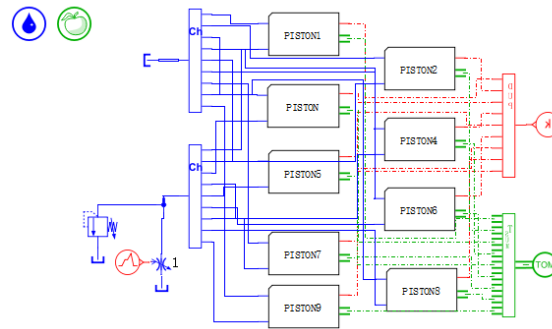

Figure 2. AMESim model of axial piston pump

Table 1. Economic Data StatisticsMain parameter settings of the plunger

Component Number	parameters	numerical value	work unit
1	Motor speed	150	rev/min
2	swashplate inclination	20	deg
3	Plunger Chamber Diameter	10	mm
	rod diameter	0	mm
4	Cavity volume	10	cm3

4. SIMULATION VERIFICATION

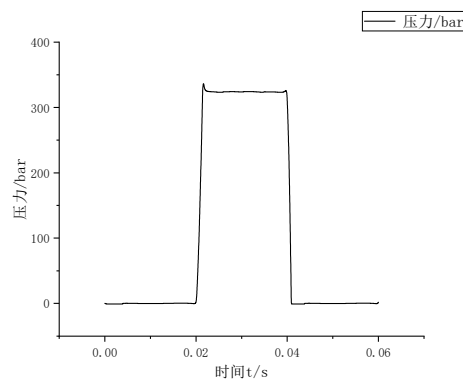

Figure 3. AMESim model of axial piston pump

As shown in Figure (refer with: Fig. 3) from the results, the plunger cavity pressure is a cyclic change, starting from zero, there is a period of negative pressure, because at first there is no oil suction, and the overcurrent area is relatively small, there will be a period of suction empty phenomenon, such as the plunger and the low-pressure cavity is completely connected to the negative pressure disappeared, along with the continued suction of oil in the wake of the inlet pressure, 0 to 180 ° has been in the suction of oil to 180 °, one after another after the high-pressure cavity in contact with the completely Out of the low-pressure chamber; discharge, the plunger cavity pressure slowly rise, there will be an overshoot phenomenon, one side of the plunger in the compression but this time the high pressure cavity of the overflow area is relatively small, the pressure will be generated by the overshoot; when fully connected to most of the high-pressure cavity, the pressure is basically maintained at about

320bar, when the plunger turned to 360 degrees when the completion of a movement cycle, suction went 180°, oil discharge also went 180°. As shown in Figure (refer with: Fig. 4) the pressure change of the plunger chamber and the low pressure area and the high pressure area of the overflow area change curve matches the match coincides.

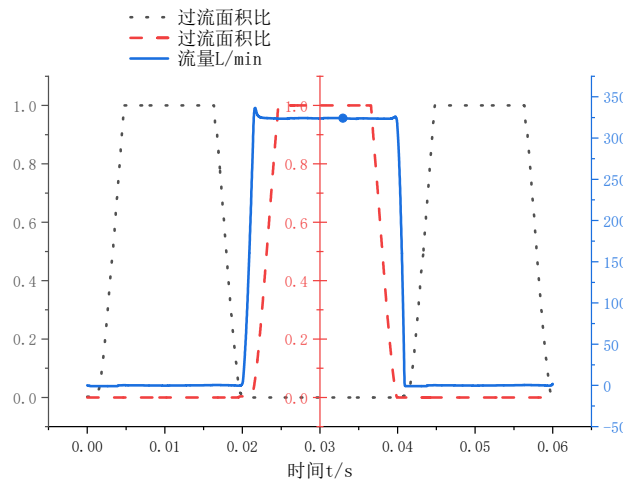

Figure 4. AMEsim model of axial piston pump

5. SIMULATION AND RESULT ANALYSIS AND OPTIMIZATION

As shown in Figure (refer with: Fig. 5) with the axial piston pump plunger outlet through the throttle groove of the distributor disk, just in contact with the throttle groove of the distributor disk can be seen, the opening angle of the V-shaped groove from 10° to 30° increase in the process of flow pulsation with the increase in the opening angle and increase, and when the complete through the throttle groove of the distributor disk, the larger the opening angle of the V-shaped groove, the smaller the flow backflow.

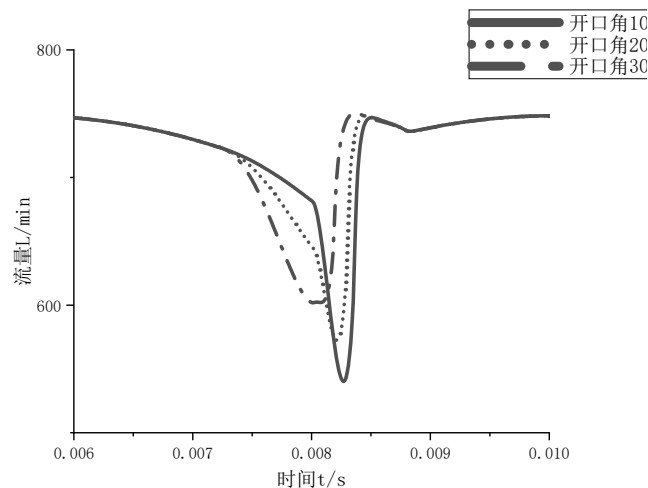

Figure 5. The influence of opening angle on flow backflow

As shown in Figure (refer with: Fig. 6) as the axial piston pump plunger outlet passes through the throttle groove of the distributor disk, it can be seen that when just in contact with the throttle groove of the distributor disk, the bottom angle of the V-groove is increased from 40° to 60° at intervals of 10°, the flow pulsation increases with the increase in the number of bottom angles, and when the complete passes through the throttle groove of the distributor disk, the bigger the bottom angle of the V-groove is, the smaller the flow backflow is.

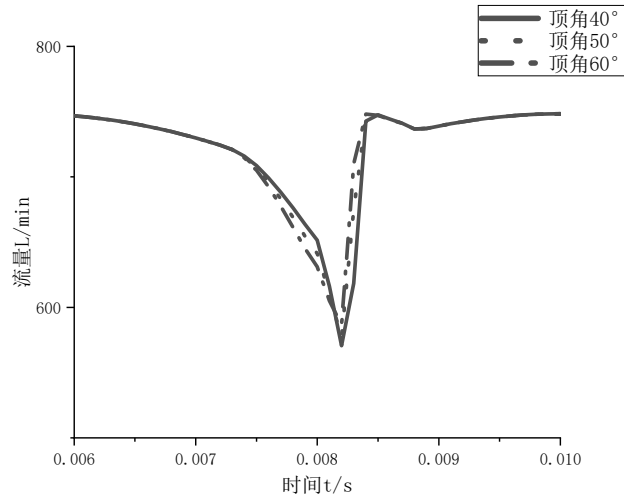

Figure 6. The influence of top angle on flow backflow

As shown in Figure (refer with: Fig. 7) with the axial piston pump plunger outlet through the throttle groove of the distributor disk, just in contact with the throttle groove of the distributor disk can be seen, the front radius of the U-shaped groove from 4mm to 2mm intervals increased to 8mm, the flow pulsation with the increase in the radius of the front of the U-shaped groove and increase, and when the complete through the throttle groove of the distributor disk, the larger the radius of the front end of the U-shaped groove, the flow of the back-up is smaller.

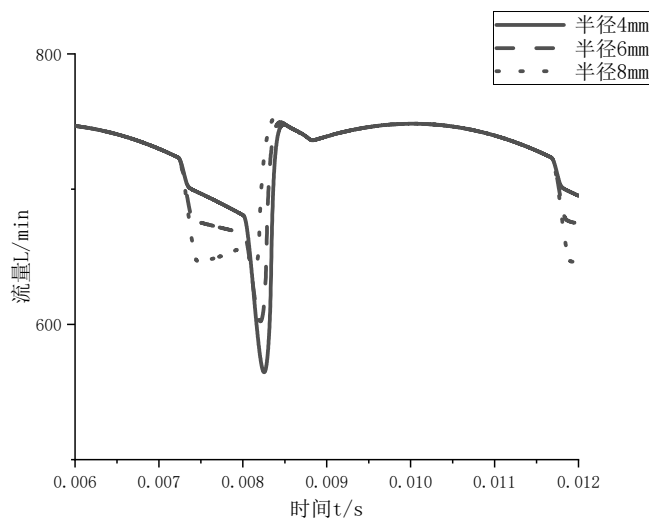

Figure 7. The influence of U-shaped groove front end radius on flow backflow

6. OPTIMIZATION OF THE STRUCTURE OF THE DAMPING GROOVE OF THE DISTRIBUTOR PLATE

In the axial piston pump work, the inlet and outlet is about to leave the distribution disk throttle groove when the slope of the overflow area curve and the inlet and outlet just contact the waist groove of the slope of the overflow area curve the more similar, the smaller the flow backflow and flow pulsation is small. According to this principle, the U-shaped groove is optimized to make it smoother in the high and low pressure areas when it is in excess, and a V-shaped opening is added at the end of the U-shaped groove for excess as shown in Fig (refer with: Fig. 8), the opening angle of the V-shaped groove is 20° , the top angle is 30° , and the semicircle radius of the front end of the U-shaped groove

is 10 mm. reducing its flow pulsation as shown in Fig (refer with: Fig. 9) and Table(refer with: Table 2), the optimized groove has a remarkable effect on improving the stability of the output flow of the axial piston pump. effect, in a cycle, the difference between the maximum and minimum values of the flow is smaller. the outlet flow pulsation rate of the U-shaped groove is 19.56%, and the outlet flow pulsation rate of the optimized groove is 16.61%, which is 2.95% less than that of U-shaped groove. Reduce the flow backflow to reduce the export flow pulsation, improve the stability of the pump and transport efficiency, thus reducing production costs, improve product quality and ensure production safety.

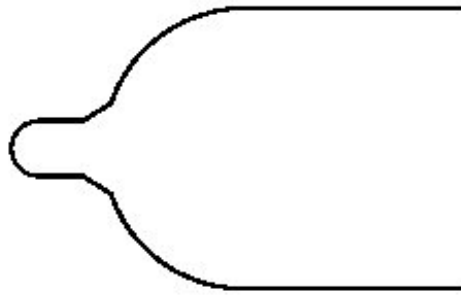

Figure 8. U-V damping groove structure

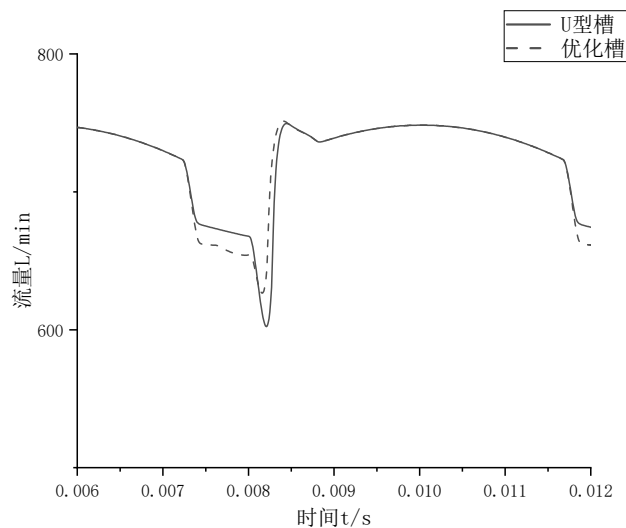

Figure 9. Comparison of flow backflow between U-shaped groove and optimized groove

Table 2. Axial piston pump flow meter

Damping groove type	Maximum flow rate L/min	Flow rate minima L/min	flow rate difference L/min
Optimization Slot	751.26	626.51	124.75
U-channel	749.02	602.49	146.53

7. SUMMARY

This paper firstly establishes the model of nine-plunger swash plate axial piston pump, and then optimizes and analyzes the flow pulsation for the damping groove of the flow distribution disk, simulates and analyzes the flow pulsation in the process of flow distribution, and researches the influence of different structures of damping groove on the flow pulsation of the pump. Then analyze the influence of key parameters of single plunger on flow pulsation and flow backflow, and the

influence of key parameters of nine-plunger swash plate axial piston pump on flow pulsation and flow backflow. Finally, the optimization of the structure of the damping groove of the distributor disk is carried out.

When the axial piston pump is working, as the axial piston pump plunger outlet passes through the throttle groove of the distribution disk, when it just contacts with the throttle groove of the distribution disk, the change of the opening angle and top angle of the V-groove causes the change of the overflow area, and the change of the radius of the front end of the U-groove causes the change of the overflow area; at this time, the larger the radius of the front end of the U-groove and the opening angle and top angle of the V-groove are, the larger the flow pulsation is, and the key parameter of throttle groove at that stage becomes positively. The key parameters of the throttle slot are negatively correlated with the flow reversal; when the complete throttle slot passes through the distribution disk, the larger the radius of the front end of the U-slot and the opening and top angles of the V-slot are, the smaller the flow reversal is, and the key parameters of the throttle slot are negatively correlated with the flow reversal in this stage. when the opening angle of the V-slot is 30° , the flow reversal is minimum as well as the flow pulsation is minimum; when the radius of the front end of the U-slot is 8 mm, the flow reversal is minimum as well as the flow pulsation is minimum; the U-slot is optimized so that it can be used in high and low pressure zones. To optimize the U-groove, a V-shaped opening is added at the end of the U-groove to make it smoother and smoother in the high and low pressure zones, the opening angle of the V-groove is 20° , the top angle is 30° , and the radius of the semicircle at the front end of the U-groove is 10mm.

REFERENCES

- [1] Zhang Junhui, Zhou Wanren, Zhao Yuming, et al. The influence of flow distribution plate on the acoustic vibration characteristics of axial piston pumps [J]. Chinese hydraulics & pneumatics, 2017 (04): 42-48.
- [2] Ji Hong, Guo Haitang, Wei Liejiang. The influence of working parameters on flow pulsation of variable piston pumps [J]. Journal of Lanzhou University of Technology, 2016,42 (05): 44-50.
- [3] LENG Xiaofeng, ZHOU Zhijin, LI Jianhua, et al. Research status of pressure pulsation characteristics of axial piston pump[J]. Hydraulics Pneumatics & Seals, 2024,44(02): 1-9.
- [4] Zha Huan. Discussion on vibration and noise issues of hydraulic piston pumps [J]. Chinese hydraulics & pneumatics, 2013 (01): 79-80.
- [5] Zhang Junhui, Xia Shiqi, Ye Shaogan, et al. Identification strategy for noise sources in axial piston pumps: simulation and testing [J]. Chinese hydraulics & pneumatics, 2017 (03): 93-100.
- [6] LI Jingwei, YANG Pan, BAO Shangling, et al. Study on distribution impact of a certain type of conical cylinder block swash plate axial piston pump[J]. Mechanical and Electrical Engineering, 2022, 39(8): 1041-1049.
- [7] LI Zhipeng, LI Yiru, WANG Jun, et al. Optimization of non-dead transition zone of distribution plate of axial piston pump[J]. Machine Tool & Hydraulics, 2022, 50(15): 121-127.
- [8] Yang Huayong, Ma Jien, Xu Bing The current research status of fluid noise in axial piston pumps [J] Journal of Mechanical Engineering, 2009,45 (08): 71-79.
- [9] LIN Jing. Calculation of interference analysis of inclined shaft axial piston pump [J]Mechanical Design and Research,2015,31(03):132-134.
- [10] YANG Kun. Research on double-row inclined axis quantitative axial piston pump[D]. Harbin: Harbin Institute of Technology,2017.
- [11] Qing Lujun, Chen Wanqiang, Li Xiangyang, et al. The influence of working parameters on the flow characteristics of axial piston pumps with inclined plungers [J]. Hydraulics Pneumatics & Seals, 2017, 37 (09): 51-55.