

# Research on Optimization of Image Recognition Algorithm Based on Deep Learning

Mingyuan Zhang

Henan University of Science and Technology University, Luoyang, China

## ABSTRACT

With the rapid development of information technology, image recognition has become increasingly crucial in numerous fields. Deep learning, as a highly potent machine learning approach, has brought about a revolutionary breakthrough in image recognition. This paper delves into the optimization of image recognition algorithms based on deep learning. Firstly, it analyzes the application status of deep learning in image recognition, covering common neural network architectures such as convolutional neural network (CNN). Then, the optimization strategy of the image recognition algorithm is elaborated from multiple aspects, including data augmentation to increase data diversity, model structure optimization for better feature extraction, and hyperparameter adjustment to enhance performance. Through extensive experiments, the effects of different optimization methods are compared meticulously. It is demonstrated that the optimized algorithm shows significant improvements in accuracy, robustness, and efficiency. Finally, the paper looks ahead to the future development trend of image recognition algorithms based on deep learning, envisioning further advancements and broader applications.

## KEYWORDS

Deep learning; Image recognition; Algorithm optimization; Convolutional neural networks

## 1. INTRODUCTION

In today's digital age, the rapid development of information technology has led to the explosion of image data at an unprecedented rate [1]. We live in a world surrounded by images, from the massive photos on social media to the complex image data in scientific research, how to accurately and efficiently identify the content of these images has become a key problem to be solved [2].

The importance of image recognition technology is self-evident, it is widely used in the field of security monitoring, can monitor and identify abnormal behaviors in real time, and plays a vital role in ensuring public safety; In terms of medical diagnosis, it assists doctors to quickly and accurately identify lesion areas and improve the efficiency and accuracy of diagnosis [3]. In autonomous driving, the image recognition of the surrounding environment realizes autonomous navigation and safe driving of the vehicle. In industrial testing, it can accurately detect product defects and quality problems, improve production efficiency and product quality. It can be said that image recognition technology is of immeasurable significance for improving production efficiency, ensuring public safety, and promoting scientific and technological innovation [4-6].

As a powerful machine learning method as Fig.1, deep learning has achieved remarkable success in the field of image recognition due to its excellent feature extraction ability and learning ability [7]. It can automatically learn rich feature representations from a large amount of image data, so as to achieve accurate classification and recognition of different types of images [8]. However, with the continuous improvement of application requirements in various fields, people have put forward more

stringent requirements for the performance of image recognition algorithms [9]. For example, in security monitoring, potential security threats need to be identified more quickly and accurately; In medical diagnosis, the recognition accuracy of minor lesions is required. Autonomous driving requires real-time and reliable image recognition in a complex and changeable environment. Therefore, it is of great practical significance to optimize the image recognition algorithm based on deep learning, which will not only help to improve the overall level of image recognition technology, but also bring new opportunities and breakthroughs to the development of various industries [10-12].

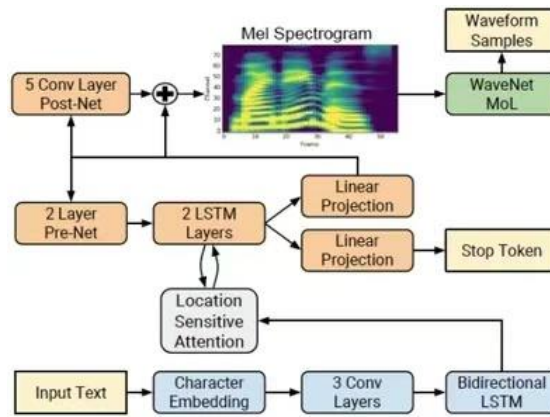

Figure 1. Deep Learning Framework

## 2. APPLICATION OF DEEP LEARNING IN IMAGE RECOGNITION

### 2.1. Basic Principles of Convolutional Neural Networks (CNNs)

As one of the key architectures used for image recognition in deep learning, convolutional neural networks play a pivotal role in the field of image recognition [13]. It is like a skilled artist, skillfully giving new life and meaning to the image through an organic combination of convolutional, pooled and fully connected layers [14].

Among them, the convolutional layer is one of the core components of the entire architecture. The convolutional layer performs meticulous convolution operations with the input image through a well-designed convolution kernel, like a keen detective, not letting go of any detail in the image, as Fig.2. These convolutional kernels are like tiny filters that can accurately capture different textures, edges, colors, and other features in an image. In the process of continuous convolution, the features of the image are gradually excavated, as if treasures hidden in the dark have been discovered one by one. Each convolutional kernel has a unique function and role, and they cooperate with each other to jointly construct a rich map of image features [15-17].

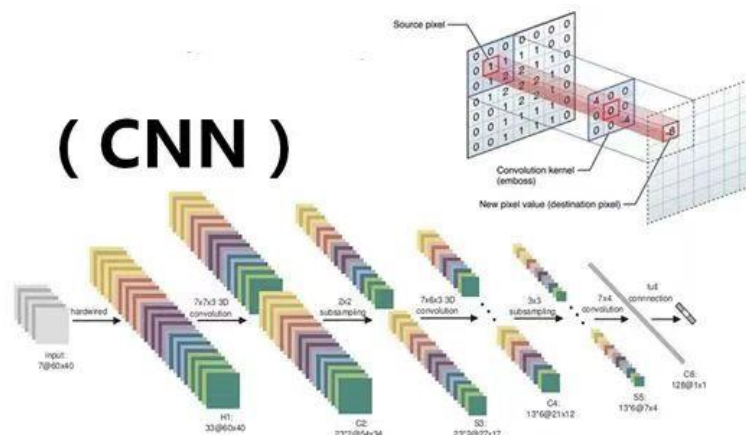

Figure 2. CNN

The pooling layer acts as an efficient compressor, downsampling the feature map obtained by the convolution operation [18]. It reduces the number of parameters and the amount of computation in a concise and powerful way, and improves the computational efficiency of the model. Pooling is like a carefully curated screening process that preserves the most critical and representative features of an image, leaving out redundant and irrelevant information. At the same time, the pooling operation can also enhance the translation invariance of the model to the image to a certain extent, so that the model can still maintain good recognition performance in the face of small displacements of the image. Just like an experienced navigator, he can accurately identify the direction of the waves, no matter how undulating the waves [19].

Finally, the fully connected layer undertakes the important task of integrating the extracted features. The fully connected layer is like an intelligent decision-maker, which comprehensively analyzes the rich features extracted from the convolutional layer and the pooling layer, and finally outputs the classification results of the image [20-22]. In this process, the fully connected layer gives full play to its powerful integration capabilities and gathers scattered feature information into a clear conclusion. Through the processing of the fully connected layer, the model can convert the features of the image into specific category labels to achieve accurate recognition of the image. It's like revealing the final mystery of a mysterious picture [23].

## 2.2. Common Deep Learning Image Recognition Models

In addition to convolutional neural networks, there are some other common deep learning image recognition models, which bring more possibilities and innovative ideas to the field of image recognition, as, Fig.3.

Recurrent Neural Network (RNN) has also shown unique application value in image recognition [24]. While RNNs are primarily useful for working with sequence data, they excel in tasks such as image description generation. It analyzes the image content frame by frame based on the input image sequence and generates a corresponding natural language description. In this way, RNNs provide a new perspective on image recognition, allowing the information of an image to be presented in a more intuitive and understandable way [25, 26]. RNN is like an imaginative poet who paints stories and emotions in images in vivid language. It is able to capture the time series relationships between images, giving the images a dynamic life.

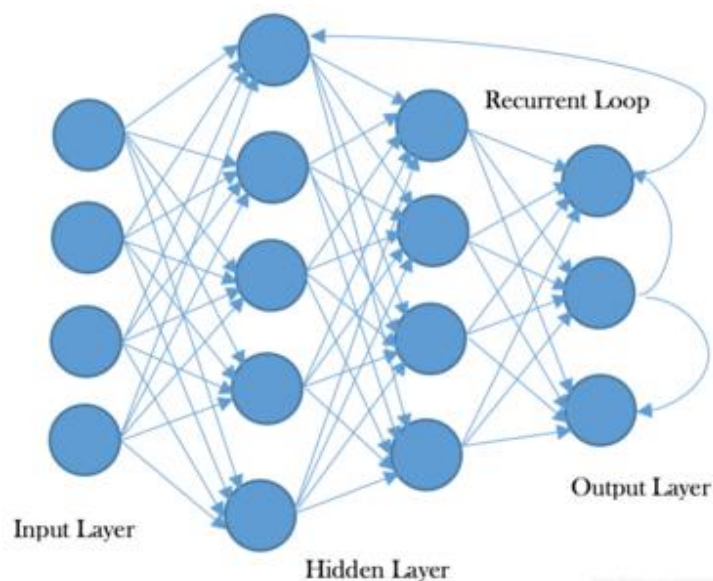

**Figure 3.** Recurrent neural networks

Generative Adversarial Networks (GANs) are a shining star in the field of image recognition. GANs can create photorealistic images through brilliant adversarial training of generators and

discriminators, as Fig.4 [27]. In this process, the generator constantly strives to produce a fake image that is as similar as possible to the real image, while the discriminator goes to great lengths to distinguish between the real image and the fake image. This fierce confrontation is like a wonderful game, and the two sides make progress together in the continuous competition. Through this adversarial training, the GAN is not only able to generate high-quality images, but can also be used for data augmentation in image recognition tasks. By generating new image data, GAN can effectively expand the training dataset, improve the generalization ability and robustness of the model, and bring new breakthroughs and progress to image recognition tasks. GAN is like a magical magician, able to conjure up a myriad of stunning images, adding infinite charm to the world of image recognition.

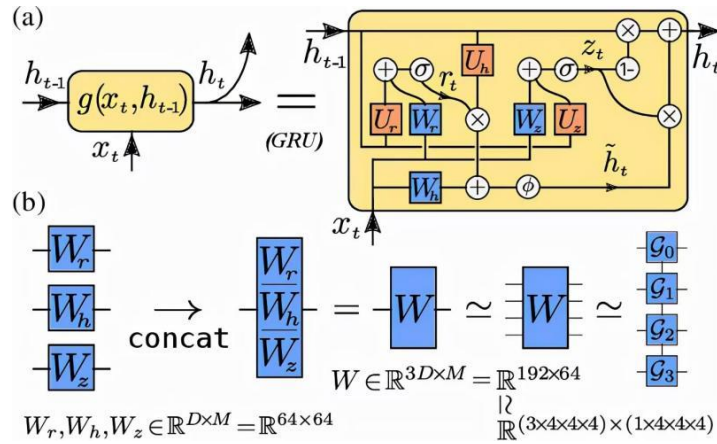

Figure 4. Generative Adversarial Networks

### 3. OPTIMIZATION STRATEGY FOR IMAGE RECOGNITION ALGORITHMS

#### 3.1. Data Augmentation

Data augmentation is undoubtedly one of the key means to improve the performance of image recognition algorithms[28]. In practical applications, the diversity of data can be greatly increased by performing a series of clever operations on the original image, such as random rotation, flipping, cropping, scaling, etc. It is like injecting new vitality and change into an originally monotonous painting, so that the model can come into contact with more image samples of different forms, so as to effectively improve the generalization ability of the model. In addition, image color transformation methods can be used, such as adjusting brightness, contrast, saturation, etc., or adding noise to simulate the possible interference of images in the real world, further enriching the diversity of data [29-31]. These data augmentation methods provide a broader training ground for the model, allowing the model to recognize various complex situations with ease.

#### 3.2. Model Structure Optimization

Improve the convolutional neural network architecture:

Increase the network depth: By reasonably increasing the number of convolutional layers and fully connected layers, the feature extraction ability of the model can be significantly improved. Just like digging for a treasure, as you dig deeper, more precious features may be discovered [32]. However, network depth that is too deep is not entirely a good thing, and it can lead to problems such as vanishing gradients and overfitting. It's like walking in a dark tunnel, you can get lost if you go too deep. Therefore, it is necessary to carefully and reasonably control the network depth to give full play to the advantages of depth while avoiding falling into the dilemma of falling into too deep.

Introduction of residual joining: The emergence of residual connection provides a good medicine for solving the gradient vanishing problem caused by the increase of network depth. It's like building a bridge on a long road so that information can be transmitted more smoothly [33]. Through residual connection, the model can better use the features of the deep network and improve the training effect, which is like injecting a strong impetus into the model, allowing it to move forward more steadily on the road of deep exploration.

Use attention mechanism: The introduction of attention mechanism allows the model to pay more attention to the key areas in the image, which greatly improves the pertinence and accuracy of feature extraction. It's like a spotlight, focusing on the most important parts of the image and excluding distractions from extraneous information. Through the attention mechanism, the model can extract key features more efficiently, thereby improving the performance of image recognition, as Fig.5.

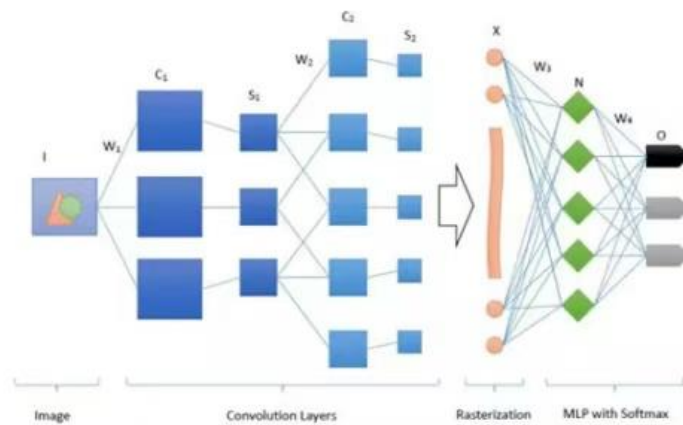

**Figure 5.** Convolutional Neural Network Structure

Fusion of multimodal information:

Combining multimodal information such as color, texture, and shape of an image for feature extraction can bring richer sources of information to the model, thereby improving the performance of the model. For example, convolutional neural networks can be combined with other feature extraction methods such as HOG (Histogram of Oriented Gradients), SIFT (Scale-Invariant Feature Transform), etc. It's like combining different instruments together to create a more beautiful movement. Different feature extraction methods have their own advantages, and by fusing multimodal information, the advantages of various methods can be fully exploited to provide stronger support for image recognition tasks [34].

### 3.3. Hyperparameter Adjustments

Hyperparameter tuning is one of the most important aspects of optimizing image recognition algorithms [35]. Common hyperparameters include learning rate, batch size, regularization coefficient, etc., which act as regulators of the model and have a significant impact on the performance of the model. The learning rate determines the step size of the parameter update during the training process, too high a learning rate may cause the model to fail to converge, and too low a learning rate will make the training process slow. The batch size affects the training efficiency and stability of the model, and a reasonable choice of batch size can find a balance between training speed and accuracy. The regularization coefficient is used to control the complexity of the model and prevent overfitting.

By properly tuning these hyperparameters, the training efficiency and accuracy of the model can be significantly improved [36]. Hyperparameter adjustments can be made using methods such as grid search, random search, and Bayesian optimization. These methods are like an experienced craftsman, meticulously crafting every parameter of the model to make it the best it can be. Grid search is like

finding the best combination of parameters in a regular grid, which is time-consuming, but ensures a comprehensive search for the best possible solution. Random search is more flexible, and it is possible to find a better solution faster by randomly trying different combinations of parameters. Bayesian optimization uses prior knowledge and probabilistic models to perform parametric search more intelligently and improve search efficiency and accuracy.

## 4. EXPERIMENTAL DESIGN AND ANALYSIS OF RESULTS

### 4.1. Experimental Datasets

In experiments, careful selection of appropriate image datasets is crucial. For example, the CIFAR-10 dataset contains 60,000 color images in 10 different categories, making it ideal for evaluating the performance of image recognition algorithms [37]. The MNIST dataset, which consists of handwritten digital images, is one of the classic datasets in the field of deep learning. The Caltech101 dataset contains 101 images of different categories, with a high level of complexity and diversity.

Rigorous preprocessing of selected datasets is an important step in ensuring experimental accuracy. First, data cleaning is carried out to remove possible noisy data and outliers to ensure the quality of the data. Next, divide the dataset into a training set and a test set. Randomization is often used to ensure that the training and test sets are representative. For example, you can follow a certain ratio, such as 70% of the images as the training set and 30% of the images as the test set.

### 4.2. Experimental Methods

In order to comprehensively evaluate the optimization effect of different optimization strategies on the image recognition algorithm based on deep learning, a variety of methods were used to conduct experiments and compare.

In terms of data augmentation, operations such as random rotation, flipping, cropping, and scaling are used to enrich the training set images. For example, for each image, a certain angle is randomly selected to rotate to increase the diversity of the data. At the same time, the image can be flipped horizontally or vertically to further enrich the data. In addition, a random portion of the image can be cropped and scaled so that the model can adapt to different sizes of images.

In terms of model structure optimization, for improving the convolutional neural network architecture, we try to increase the number of convolutional layers and fully connected layers to observe the impact of network depth on performance. For example, the number of convolutional layers and fully connected layers is gradually increased, the network structure is gradually deepened, and the accuracy of the model at different depths and other performance indicators are recorded. When the residual connection is introduced, the residual module is added at an appropriate position in the network to observe the convergence and performance improvement of the model during the training process. When using the attention mechanism, different types of attention modules, such as spatial attention and channel attention, are selected and applied to the model respectively, and their improvement effect on the pertinence and accuracy of feature extraction is compared.

In terms of fusing multimodal information, convolutional neural networks are combined with feature extraction methods such as Histogram of Oriented Gradients (HOG) and Scale-Invariant Feature Transform (SIFT). Firstly, different feature extraction methods are used to extract the features of the image, and then these features are fused and input into the classifier for training and testing.

In the experiment, the accuracy, recall, F1 value and other indicators were used to evaluate the performance of the algorithm. Accuracy refers to the ratio of the number of samples correctly classified to the total number of samples, reflecting the overall accuracy of the algorithm. The recall rate refers to the ratio of the number of correctly classified positive samples to the actual number of

positive samples, which reflects the algorithm's ability to identify positive samples. The F1 value is the harmonized average of accuracy and recall, taking into account the accuracy and recall of the algorithm.

### 4.3. Analysis of Experimental Results

Detailed and in-depth analysis of the experimental results was carried out to comprehensively compare the effects of different optimization methods.

Firstly, the improvement of the accuracy of the algorithm by different optimization methods was observed. By comparing the accuracy indicators before and after optimization, we can intuitively see the impact of data augmentation, model structure optimization, and hyperparameter adjustment on the accuracy of the algorithm. For example, a model may be 75% more accurate on a CIFAR-10 dataset than 70% after data augmentation. By improving the convolutional neural network architecture and introducing methods such as residual connection or attention mechanisms, the accuracy may be further improved to 80% or even higher.

The robustness of the optimized algorithm is analyzed. By adding noise to the test set and changing the lighting conditions, the interference in the actual application is simulated and the performance change of the algorithm is observed. If the optimized algorithm can still maintain a high accuracy in the face of these interferences, it indicates that it has good robustness. For example, after adding a certain intensity of Gaussian noise to the image, the accuracy of the unoptimized algorithm decreases by 10%, while the accuracy of the optimized algorithm decreases by only 5%, indicating that the optimized algorithm is more resistant to noise.

At the same time, the efficiency improvement of the optimized algorithm was evaluated. Record the training time and inference time of the model, and compare the computing resource consumption before and after optimization. If the optimized algorithm can complete training and inference in less time, or process more image data in the same time, its efficiency is improved. For example, a model before optimization takes 100 milliseconds to process an image, while an optimized model may take only 50 milliseconds.

Discuss the strengths and weaknesses of the optimization approach. The advantage of the data augmentation method is that it is simple and easy to implement, which can effectively improve the generalization ability of the model, but may increase the computation cost and training time. The model structure optimization method can significantly improve the performance of the algorithm, but it requires more computing resources and experience in parameter tuning. Hyperparameter tuning methods can be optimized for specific problems, but they take a lot of time to search and experiment.

Through the comprehensive analysis of the experimental results, it can provide a strong basis and guidance for the optimization of image recognition algorithms based on deep learning, and further promote the development and application of image recognition technology.

## 5. CNCLUSIONS

In this paper, the image recognition algorithm based on deep learning is studied in depth, and a series of optimization strategies are proposed. Experiments verify the effectiveness of these optimization strategies and improve the performance of image recognition algorithms.

## REFERENCES

- [1] Zhong, Y., Liu, Y., Gao, E., Wei, C., Wang, Z., & Yan, C. (2024). Deep Learning Solutions for Pneumonia Detection: Performance Comparison of Custom and Transfer Learning Models. medRxiv, 2024-06.

- [2] Gu, W., Zhong, Y., Li, S., Wei, C., Dong, L., Wang, Z., & Yan, C. (2024). Predicting Stock Prices with FinBERT-LSTM: Integrating News Sentiment Analysis. arXiv preprint arXiv:2407.16150.
- [3] Liu, J., Li, K., Zhu, A., Hong, B., Zhao, P., Dai, S., ... & Su, H. (2024). Application of Deep Learning-Based Natural Language Processing in Multilingual Sentiment Analysis. *Mediterranean Journal of Basic and Applied Sciences (MJBAS)*, 8(2), 243-260.
- [4] Xu, Q., Feng, Z., Gong, C., Wu, X., Zhao, H., Ye, Z., ... & Wei, C. (2024). Applications of Explainable AI in Natural Language Processing. *Global Academic Frontiers*, 2(3), 51-64.
- [5] Gao, H., Wang, H., Feng, Z., Fu, M., Ma, C., Pan, H., ... & Li, N. (2016). A novel texture extraction method for the sedimentary structures' classification of petroleum imaging logging. In *Pattern Recognition: 7th Chinese Conference, CCPR 2016, Chengdu, China, November 5-7, 2016, Proceedings, Part II 7* (pp. 161-172). Springer Singapore.
- [6] Li, W., Li, H., Gong, A., Ou, Y., & Li, M. (2018, August). An intelligent electronic lock for remote-control system based on the internet of things. In *Journal of physics: conference series* (Vol. 1069, No. 1, p. 012134). IOP Publishing.
- [7] Wang, Z., Yan, H., Wei, C., Wang, J., Bo, S., & Xiao, M. (2024). Research on Autonomous Driving Decision-making Strategies based Deep Reinforcement Learning. arXiv preprint arXiv:2408.03084.
- [8] Bo, S., Zhang, Y., Huang, J., Liu, S., Chen, Z., & Li, Z. (2024). Attention Mechanism and Context Modeling System for Text Mining Machine Translation. arXiv preprint arXiv:2408.04216.
- [9] Zhou, R. (2024). Understanding the Impact of TikTok's Recommendation Algorithm on User Engagement. *International Journal of Computer Science and Information Technology*, 3(2), 201-208.
- [10] Zhou, R. (2024). Advanced Embedding Techniques in Multimodal Retrieval Augmented Generation a Comprehensive Study on Cross Modal AI Applications. *Journal of Computing and Electronic Information Management*, 13(3), 16-22.
- [11] Zhang, Y., & Fan, Z. (2024). Memory and Attention in Deep Learning. *Academic Journal of Science and Technology*, 10(2), 109-113.
- [12] Zhang, Y., & Fan, Z. (2024). Research on Zero knowledge with machine learning. *Journal of Computing and Electronic Information Management*, 12(2), 105-108.
- [13] Wang, J., Zhang, H., Zhong, Y., Liang, Y., Ji, R., & Cang, Y. (2024). Advanced Multimodal Deep Learning Architecture for Image-Text Matching. arXiv preprint arXiv:2406.15306.
- [14] Wang, J., Li, X., Jin, Y., Zhong, Y., Zhang, K., & Zhou, C. (2024). Research on image recognition technology based on multimodal deep learning. arXiv preprint arXiv:2405.03091.
- [15] Yao, Y. (2024, May). Design of Neural Network-Based Smart City Security Monitoring System. In *Proceedings of the 2024 International Conference on Computer and Multimedia Technology* (pp. 275-279).
- [16] Xu, T. (2024). Comparative Analysis of Machine Learning Algorithms for Consumer Credit Risk Assessment. *Transactions on Computer Science and Intelligent Systems Research*, 4, 60-67.
- [17] Xu, T. (2024). Credit Risk Assessment Using a Combined Approach of Supervised and Unsupervised Learning. *Journal of Computational Methods in Engineering Applications*, 1-12.
- [18] Xia, Y., Liu, S., Yu, Q., Deng, L., Zhang, Y., Su, H., & Zheng, K. (2023). Parameterized Decision-making with Multi-modal Perception for Autonomous Driving. arXiv preprint arXiv:2312.11935.
- [19] Qiu, L., & Liu, M. (2024). Innovative Design of Cultural Souvenirs Based on Deep Learning and CAD.
- [20] Liu, M., & Li, Y. (2023, October). Numerical analysis and calculation of urban landscape spatial pattern. In *2nd International Conference on Intelligent Design and Innovative Technology (ICIDIT 2023)* (pp. 113-119). Atlantis Press.
- [21] Lin, Y. Discussion on the Development of Artificial Intelligence by Computer Information Technology.
- [22] Lin, Y. (2023). Optimization and Use of Cloud Computing in Big Data Science. *Computing, Performance and Communication Systems*, 7(1), 119-124.
- [23] Lin, Y. (2024). Application and Challenges of Computer Networks in Distance Education. *Computing, Performance and Communication Systems*, 8(1), 17-24.
- [24] Lin, Y. (2024). Design of urban road fault detection system based on artificial neural network and deep learning. *Frontiers in neuroscience*, 18, 1369832.
- [25] Lin, Y. (2023). Construction of Computer Network Security System in the Era of Big Data. *Advances in Computer and Communication*, 4(3).
- [26] Yang, J. (2024). Data-Driven Investment Strategies in International Real Estate Markets: A Predictive Analytics Approach. *International Journal of Computer Science and Information Technology*, 3(1), 247-258.
- [27] Yang, J. (2024). Comparative Analysis of the Impact of Advanced Information Technologies on the International Real Estate Market. *Transactions on Economics, Business and Management Research*, 7, 102-108.

- [28] Yang, J. (2024). Application of Business Information Management in Cross-border Real Estate Project Management. *International Journal of Social Sciences and Public Administration*, 3(2), 204-213.
- [29] Wang, C., Yang, H., Chen, Y., Sun, L., Zhou, Y., & Wang, H. (2010). Identification of Image-spam Based on SIFT Image Matching Algorithm. *JOURNAL OF INFORMATION & COMPUTATIONAL SCIENCE*, 7(14), 3153-3160.
- [30] Wang, C., Yang, H., Chen, Y., Sun, L., Wang, H., & Zhou, Y. (2012). Identification of Image-spam Based on Perimetric Complexity Analysis and SIFT Image Matching Algorithm. *JOURNAL OF INFORMATION & COMPUTATIONAL SCIENCE*, 9(4), 1073-1081.
- [31] Wang, C., Sun, L., Wei, J., & Mo, X. (2012). A new trojan horse detection method based on negative selection algorithm. In *Proceedings of 2012 IEEE International Conference on Oxide Materials for Electronic Engineering (OMEE)* (pp. 367-369).
- [32] Sun, L. (2023). A New Perspective on Cybersecurity Protection: Research on DNS Security Detection Based on Threat Intelligence and Data Statistical Analysis. *Computer Life*, 11(3), 35-39.
- [33] Sun, L. (2024). Securing supply chains in open source ecosystems: Methodologies for determining version numbers of components without package management files. *Journal of Computing and Electronic Information Management*, 12(1), 32-36.
- [34] Tu, H., Shi, Y., & Xu, M. (2023, May). Integrating conditional shape embedding with generative adversarial network-to assess raster format architectural sketch. In *2023 Annual Modeling and Simulation Conference (ANNSIM)* (pp. 560-571). IEEE.
- [35] Shi, Y., Ma, C., Wang, C., Wu, T., & Jiang, X. (2024, May). Harmonizing Emotions: An AI-Driven Sound Therapy System Design for Enhancing Mental Health of Older Adults. In *International Conference on Human-Computer Interaction* (pp. 439-455). Cham: Springer Nature Switzerland.
- [36] Soana, V., Shi, Y., & Lin, T. A Mobile, Shape-Changing Architectural System: Robotically-Actuated Bending-Active Tensile Hybrid Modules.
- [37] Zhang, Y., Yang, K., Wang, Y., Yang, P., & Liu, X. (2023, July). Speculative ECC and LCIM Enabled NUMA Device Core. In *2023 3rd International Symposium on Computer Technology and Information Science (ISCTIS)* (pp. 624-631). IEEE.