

Design Of High-Altitude Falling Object Alert System

Xinyue Dong

School of Electronic Information and Artificial Intelligence, Shaanxi University of Science and Technology, Xi'an 710000, China

ABSTRACT

As urbanization accelerates, the number of high-rise buildings in cities has increased significantly, leading to frequent incidents of objects falling from great heights. These incidents pose a serious threat to public safety and property. This paper describes the design and implementation of a real-time monitoring and alert system for high-altitude falling objects aimed at enhancing urban safety management efficiency and effectiveness. This paper describes the design and implementation of a real-time monitoring and alert system for high-altitude falling objects aimed at enhancing urban safety management efficiency and effectiveness. The system employs an STM32 controller to monitor and alert the falling objects. system employs an STM32F103C8T6 microcontroller as its core processor, coupled with two infrared sensors and an ESP32-CAM camera for detection purposes. It assesses the presence of falling objects by analyzing signals from these sensors and alerts pedestrians through LED indicators and buzzers. It assesses the presence of falling objects by analyzing signals from these sensors and alerts pedestrians through LED indicators and buzzers. Additionally, it includes a mobile app for remote monitoring, enabling users to check conditions and respond promptly. The system's design and accuracy were further validated through simulation experiments conducted with Python, which confirmed that the alert system reliably detects falling incidents and promptly issues warnings, thereby reducing the number of pedestrians and alerts pedestrians through LED indicators and buzzers. The system's design and accuracy were further validated through simulation experiments conducted with Python, which confirmed that the alert system reliably detects falling incidents and promptly issues warnings, thereby significantly improving safety measures.

KEYWORDS

High-Altitude Falling Objects; Real-time Monitoring; STM32; ESP32-CAM; Safety Alerts

1. INTRODUCTION

1.1. Background of the Study

In today's modern urban life, due to the increasing number of high-rise buildings in the city, the frequency of falling objects from height has been increasing year by year, which has become a major hidden danger in urban safety management. According to the research paper by Zhang Lei et al, falling objects from heights not only pose a life threat to passing pedestrians, but also may lead to serious property losses [1]. The falling objects may also cause serious property damage. Therefore, reports of similar incidents appear in the society from time to time, and each time they cause widespread concern and worry. The random and unpredictable nature of such incidents makes traditional preventive measures such as warning signs as well as barriers less effective. Therefore, how to effectively monitor and warn of falling objects from heights in order to minimize the safety hazards they pose has become an urgent issue.

In recent years, incidents of objects being thrown from a height and falling objects have occurred frequently throughout the country, seriously affecting public safety and the safety of people's lives and property. Due to the difficulty of investigation and evidence collection, the victim's rights and compensation and many other problems, resulting in the prevention and punishment of the phenomenon of objects thrown from a height and falling objects is more difficult, and the public has a strong reaction. In this regard, in order to conscientiously implement the General Secretary Xi Jinping "efforts to promote the modernization of municipal social governance pilot" important instructions, closely around the 19th CPC National Congress on "improve the level of protection and improvement of people's livelihoods, strengthen and innovate social governance," the industry-related units have developed the overhead throwing phenomenon. Units have developed overhead throwing monitoring solutions, can be thrown from a height, falling objects to implement a panoramic trajectory retrospective, automatic forensics fixed evidence, integrated monitoring and early warning, mining data value, effectively deterring the habit of throwing objects from a height, falling objects, and effectively guarding the masses of the "overhead safety". [23] The data will be used to effectively deter the habit of throwing and falling objects from height, and effectively guard the public's "overhead safety".

At the same time, with the development of the Internet of Things and intelligent monitoring technology, people have begun to explore the use of technical means to solve this problem. For example, Liu Jingqi's team proposed a monitoring system based on ultrasonic detection and cloud Internet of Things, which can to a certain extent carry out real-time monitoring and alarms for throwing objects from a height, and the article mentioned that the current measures at home and abroad to cope with throwing objects from a height can be broadly categorized into two categories: prevention and treatment after the incident. [16] Preventive measures include the prohibition of throwing objects from heights. Preventive measures include publicity and education to prohibit throwing objects from height and legislation to warn and combat the evil disease of throwing objects from height, while post-procedural measures are to utilize equipment to capture evidence and focus on solving the case at a later stage. In the prevention beforehand, small and medium-sized floors are mostly chosen to install additional extension guards on the building's outer wall, with composite bearing structure to undertake falling objects; in the aftermath of the responsibility, some high-grade communities set up surveillance cameras to capture and video recording, to achieve the archives retained and responsibility for the pursuit of [2]. However, most of these systems are often limited to monitoring and early warning, and cannot provide substantial protection in the event of falling objects.

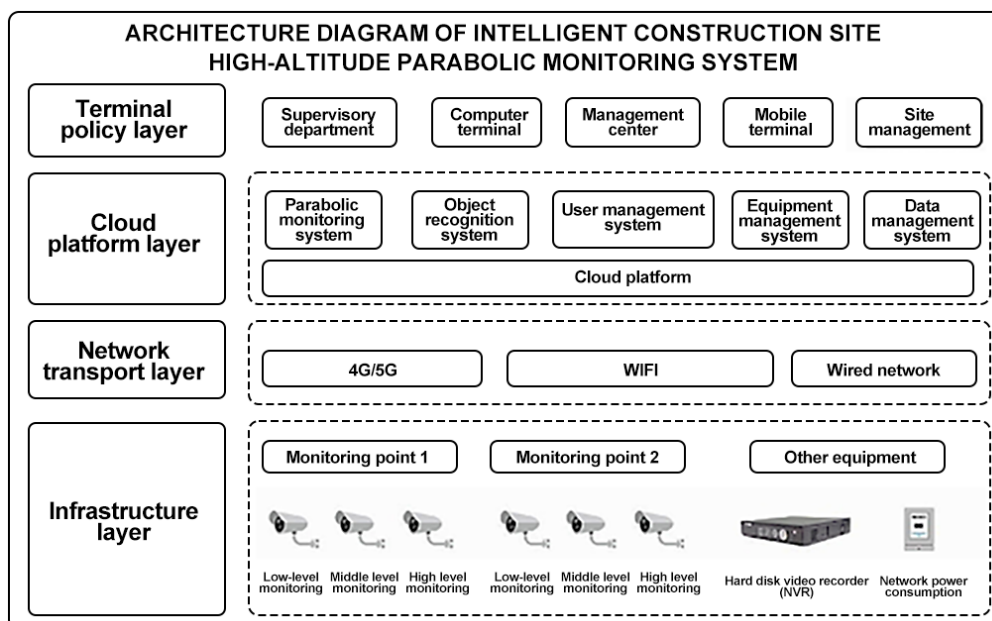

Figure 1-1. Architecture diagram of Cloud IOT overhead throwing detection system [2]

To fill this gap, this paper is dedicated to the development of a system that not only monitors and warns in real time, but also automatically deploys protective measures when falling objects are detected. This system aims to reduce the threat to people's life and property safety from falling objects events through technical means, while improving the sense of safety and well-being of urban residents.

1.2. Demand Analysis for Falling Objects Warning and Protection Systems

The demand for early warning of falling objects and the establishment of protection systems comes from two main sources: the general concern for public safety and the technological pursuit of efficient safety management tools. As mentioned in the study by Lawrence Zhang and his team, due to people's emphasis on their own safety and the increasing demand for relevant early warning systems, the need for early warning systems is becoming more and more urgent [3]. This demand drives technology developers to look for solutions that can instantly respond to falling objects. On the technical level, Yang et al. show that with the development of the economy, the number of building floors is increasing, and the danger of falling objects is getting bigger and bigger in some accident-prone locations, such as construction sites. Although monitoring systems based on various sensor technologies are available in the market, most of them still remain at the warning stage and lack effective physical interventions [3].

In addition, the current system generally suffers from the problems of long response time, high false alarm rate and single protection measure, the existence of which limits the practical application scope of the early warning system and its effectiveness. In order to solve these problems, this study proposes a new approach, i.e., the use of advanced sensor technology and micro-control unit, through real-time data processing and microcontroller intelligent algorithms, which not only accurately monitors the events of falling objects, but also deploys the activation of the capture network in a very short time, effectively preventing or mitigating the damages caused by the falling objects.

Falling objects from heights are not uncommon in today's increasingly high-rise buildings. From Zhu Xiaoqin's research, with the sustained development of the economy, urbanization deepens, throwing objects from a height is becoming increasingly serious, and the harm caused by it is also becoming more and more serious, the thesis mainly tells, at present, for the behavior of throwing objects from a height and the development of the monitoring system for throwing objects from a height of the different ways of building the system and the corresponding applicable scenarios, and introduces the selection of its front-end equipment recommendations [22]. The front-end equipment selection suggestions are also introduced. In specific cases, the specific case situation there are differences, need to be based on relevant evidence to determine the specific subject of compensation. If there is other evidence showing that the property company has inadequate supervision or negligence, the property company may be held liable at the same time. In similar circumstances, it is recommended that the parties concerned retain the relevant evidence (e.g. surveillance video, investigation report, etc.) in a timely manner and negotiate with the relevant responsible parties to resolve the dispute as soon as possible. If no agreement can be reached, a fair judgment can be sought from the court by way of prosecution [19].

After reviewing some of the legal literature on falling objects from a height, it is understood that, from past experience, there is no major controversy in the jurisprudence on the nature of the determination of the behavior of throwing and falling objects from a height and the assumption of responsibility, and the difficulty and the pain point lies in the fact that, "it is necessary to promptly and accurately identify the responsible person, which requires the public security organs and other relevant organs to promptly investigate and carefully identify the responsible person ". This is because on the civil side, according to the law, if the person who threw the object cannot be clearly identified, the occupants who may have thrown the object will be jointly liable for the civil tort liability [18]. The civil aspect is that, according to the law, if the person who threw the object cannot be identified, the tenants who may have thrown the object are jointly liable for civil liability. Therefore, in terms of

monitoring the scene, there must also be a certain degree of technical embodiment. The demand for this system reflects the current expectations of society for high-tech security products, while reflecting the rapid development of urbanization in the process of improving urban security level, the urgent need to protect the lives and property of citizens.

1.3. Purpose and Significance of the Study

The aim of this study is to design and implement an intelligent early warning system for falling objects that integrates monitoring, warning and protection. The purpose of this study is not only to accurately monitor the occurrence of falling objects, but also to ensure the protection of people and property through the rapid deployment of a capture network. Through this system, not only the threat of falling objects to urban safety can be significantly reduced, but also the possibility of human casualties and property damage can be minimized.

On the technical level, the significance of this study is reflected in the improvement and innovation of the existing technology. By analyzing the paper of Zhang Yu et al, we learned how to effectively monitor overhead objects using modern electronic technology and sensor networks. In the paper, an intelligent monitoring system for overhead objects is designed based on ultrasonic ranging principle and cloud IOT technology. Compared with the existing technology, this design has the advantages of high monitoring sensitivity, low cost, not affected by the weather environment, etc. It can accurately locate the specific position of the objects thrown from height and send real-time alarm signals to remind the pedestrians on the road to avoid them in time, which can play the role of both after-the-fact recourse and before-the-fact prevention [6]. On this basis, this study proposes a system design that integrates the use of infrared sensors, microcontrol units (MCUs), and camera modules, which are able to capture the signals of falling objects more sensitively and accurately determine the potential dangers through image algorithms.



Figure 1-2. Detection of sensing through ultrasonic sensors combined with IoT [6]

On the social level, the practical significance of this system is to enhance public safety and promote the modernization of urban management. Although the management of falling objects is difficult, the exploration of management measures has not stopped, but the main idea is to focus on finding the person responsible for throwing objects (falling objects) and make them responsible. From Guo Daojiu's article we also learned about a "one network unified management" system, in real life has also been fully utilized. Intelligent "a network of unified management" in addition to the continuation of the idea of responsibility, pay more attention to the prevention of [21]. In addition to the continuation of the idea of responsibility, more attention is paid to prevention. How to protect urban residents from the threat of falling objects is currently an important issue facing urban management. He Guangcheng's research pointed out that the microcontroller-based early warning system can effectively prevent injuries caused by falling objects [8]. And this study will further integrate the

capture net in such system to improve the practicality and protection ability of the early warning system.

1.4. Current Status and Development Trend of Domestic and Overseas Research

1.4.1. Status of domestic research

In China, research investigations on falling objects have mainly focused on the development of monitoring systems and early warning systems for falling objects. In recent years, due to the gradual deepening of China's urbanization level and the rapid growth of the number of high-rise buildings in cities, the research related to falling objects from heights has been developed rapidly. Such as Chongqing University, Liu Yuchen's research, in its thesis proposed the realization of lawn mower obstacle detection system, the first selection and construction of lawn mower obstacle detection hardware system, and then training and integration of the yolov3 target detection model, transplanted to the embedded system for the hardware side of the acceleration, to ensure that the target detection algorithms integrated in the lawn mower mobile hardware system can run in real time. At the same time, the video stream acquired by the camera on the embedded development end is utilized to detect the obstacles represented by people, etc., appearing in the video, and to react to a certain range of obstacles such as the envelope. The principles of this detection technique can be similarly borrowed for monitoring potential falling objects at high altitude [11]. Meanwhile, the research of Xia Changyu et al. is more concerned with the design of a multifunctional detection module integrating temperature, sound and distance detection, from which it is understood that infrared sensors, ultrasonic sensors and sound detection modules are characterized by small size and high sensitivity, the STM32 microprocessor has the advantages of high performance, low cost and low power consumption, and the wireless transmission module can ignore the influence of the terrain to a certain extent. The temperature, sound and distance detection device composed of sensor and microprocessor is easy to carry, low cost and good performance. With the development of future technology, the sensor performance is bound to get better and better, its accuracy, detection distance will have a greater improvement, the processing capacity of the processor will also have a great progress, the wireless transmission module of the information transmission distance, stability can be strengthened. This kind of multi-module integrated module will provide a new idea for the early warning system of falling objects from heights [12].

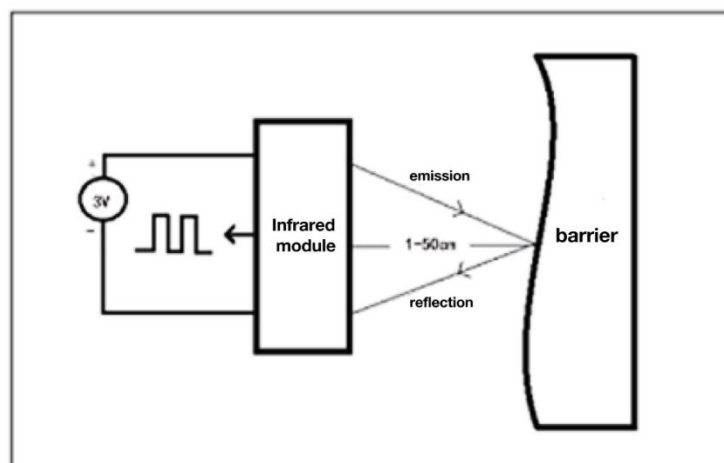

Figure 1-3. Schematic diagram of temperature, sound and distance detection module [12]

Similarly, the research of Qin Qinglei's team also proposes an ultra-low-power infrared obstacle detection module design, in which the infrared detection module is used to emit a specific frequency of pulsed infrared light, and use the infrared photosensitive receiver tube to receive the reflected light in front, and determine the distance to the obstacle based on the intensity of the received light. Due to its simple structure and low cost, it is mostly used for non-contact distance measurement, obstacle

detection, obstacle color detection and other devices. Because of its low power consumption, this technology is also very suitable for long-time operation of the falling object monitoring system [13]. The technology is also well suited for long-time operation of falling object monitoring systems. In addition, Sun Jingwei and his colleagues in the design of intelligent detection of falling objects early warning system, the use of Internet of Things technology to achieve the remote transmission of data and real-time processing [5]. The system is also very suitable for long time operation.

In further research, there are also many good solutions to the problem of falling objects from height. For example, the team of He Guangcheng designed an STM32 microcontroller-based fall prevention system, and proposed an innovative program combining mechanical devices and electronic technology in its thesis. This kind of system collects associated data such as speed, space and motion in real time through infrared, image recognition, speed and other sensors, applies an automatic control program, carries out the system's logic processing and mathematical operations, and uses infrared signal detection, camera image recognition and other technologies to identify whether an object at high altitude has crossed the protection zone (wanting to fall down from a height protection zone), or to monitor whether there are falling objects falling from the outer altitude of the high-rise building, and at the same time, according to the speed sensor to derive the speed and size of the falling object, and further control the status and number of triggering protection network devices to realize the alarm of the objects wanting to fall from height and the protection of falling objects [8]. In addition, the research of Yang Wenhai and Lv Yaohui also focuses on the intelligent monitoring and warning system, especially on the innovation of data processing of falling objects and user interaction of the warning interface [4]. Their research incorporates user feedback into the system design, which improves the practicality of the system and allows it to be updated and iterated according to user needs. In the research of Li Qiu Hao and Jia Xiao Qiang, the application of the concept of interception of falling objects was also proposed, and they designed a protection system for interception and forensics of falling objects, in which there are two ways of detecting falling objects: (1) radar detection of falling objects in the interception subsystem, and (2) video recognition detection of falling objects in the forensics subsystem. The detection of falling objects in either of the two ways can activate the interception board, record the time of video surveillance at this moment, and issue a warning message, which also brings a new point of thinking for this study [7].

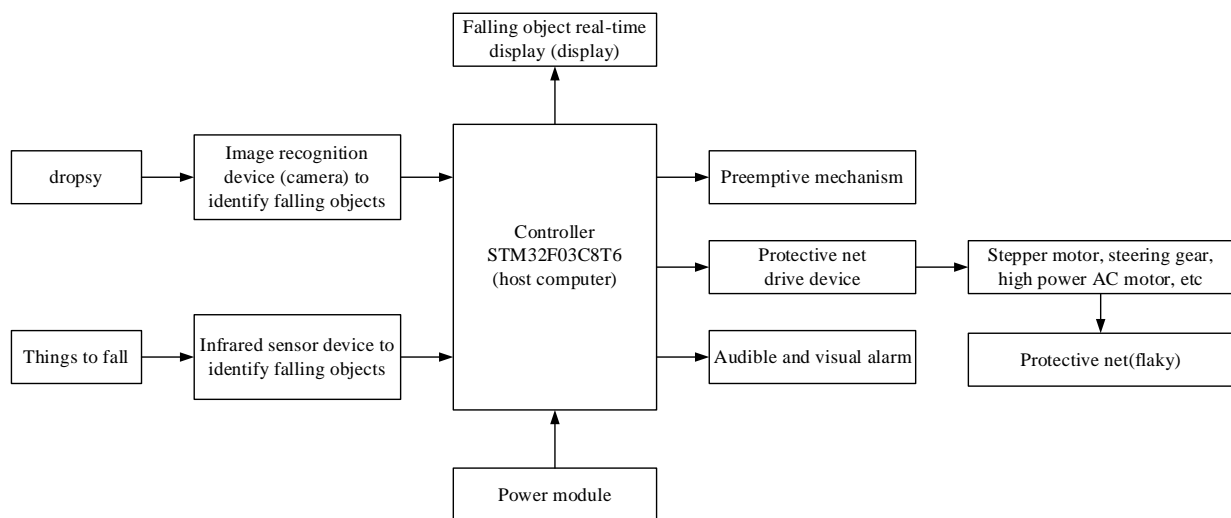

Figure 1-4. Block diagram of STM32 microcontroller overhead fall prevention system [8]

Therefore, at the practical application level, city managers and technology developers in China have already started to implement urban safety management systems including falling objects monitoring. For example, in Zhou Tao's patent an early warning system for falling objects for construction sites, it is possible to understand how early warning of falling objects can be realized in relation to specific practical contexts such as construction sites. In the invention in order to avoid the sound of the alarm horn by the construction site of the noisy sound cover, set up a display, the display of the up and down

position can be adjusted, can be adjusted to the human eye to observe and does not block people's line of sight to the position, but also directly upward adjustment of the display flipped over the fixed. Through other people to observe, so that people working together can observe each other's monitor to give each other a reminder to ensure the relative security [9]. Among them, the government's policy support and financial investment have provided the impetus for the research and development of these technologies. However, it is still a great challenge for domestic research institutes to transform these research results into reliable, effective and economical practical applications.

1.4.2. Current status of foreign research

At the international level, there is a diversifying trend in research on monitoring and early warning systems for falling objects. Many research organizations and universities are exploring the use of high-tech means to solve safety problems caused by falling objects. For example, in the study by Yu Duan et al, which employs microfluidic devices for high spatial efficiency single-particle capture arrays, the article describes the realization of high-throughput single-particle capture through the design of microfluidic devices with microcup arrays. This likewise provides new ideas for capture net technology in capturing and protecting against falling objects at high altitudes [10]. The technology provides new ideas for the capture and protection of falling objects at high altitudes. This technology opens up the possibility of capturing suspended falling objects in the atmosphere and indirectly contributes to the development of falling object protection technology.

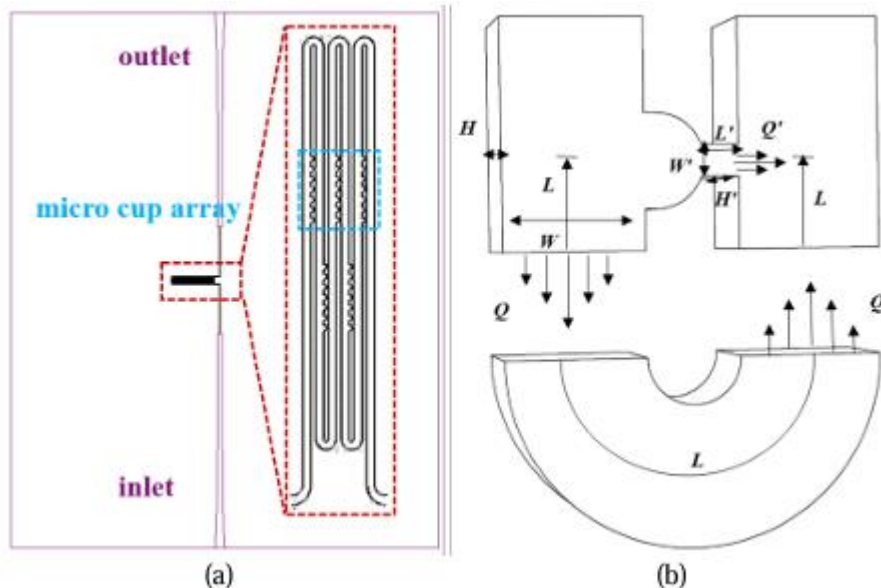

Figure 1-5. (a) Schematic of microfluidic device [10](b) Schematic diagram of the microcup used to capture cells [10]

In addition, the microcontroller-based data acquisition system developed by N C Ryder et al. exemplifies the advanced application of sensor technology in the field of data acquisition [14]. This provides reliable technical support for data processing and analysis in falling object monitoring systems, which are more refined in terms of accuracy and response speed requirements. The research of Shakeel Akram and Farhan Hameed Malik, on the other hand, focuses on microcontroller-based intelligent control systems that can automatically adjust their operating posture to cope with environmental changes [15]. This adaptability is essential for the stability and reliability of the Falling Object Monitoring System (FOMS).

In terms of practical application, some foreign cities have also begun to deploy high-altitude monitoring systems to protect public safety. These systems usually combine video surveillance, sensor networks and automatic alert mechanisms with a view to achieving real-time monitoring of falling objects and rapid response. This indicates a trend whereby urban safety management is shifting from traditional reactive protection to active monitoring and early warning.

International research has made significant progress in sensor technology, data processing, and system integration, but there is still much room for development in the practical deployment and application of actual physical protection measures - especially capture network technology. In the future, the results of these studies are expected to provide more efficient and smarter solutions for global urban safety management.

1.4.3. Development trends

Comprehensive research status at home and abroad, the monitoring and early warning system for falling objects has become a multidisciplinary research hotspot, and different countries and research teams have put forward a variety of solutions for the actual situation of cities in their respective countries. Domestic research focuses on the application of sensors and the development of microcontrollers, striving to optimize the monitoring accuracy and system response speed. Foreign research is more mature in terms of sensor technology, data processing capability and system adaptability.

The international research is usually more open and innovative, for example, its application in microfluidic devices and data acquisition systems provides a new way of thinking about the accuracy and adaptability of the falling objects monitoring system at high altitude. Domestic research is more pragmatic at the application level, focusing more on solving specific technical problems, such as Qin Qinglei's design of an ultra-low-power infrared obstacle detection module, which is of great practical value [13]. For example, Qin Qinglei's design of ultra-low-power infrared obstacle detection module is very practical.

The combination of the two helps to promote technological advancement in the whole field. For example, XIN ZHANG's research has led to a good combination of electronic and mechanical technologies to produce a three-part automated device for preventing falling objects from heights, namely, the Falling Object Detection and Recognition System (ODRS), the Motion Control System, and the Pneumatic Structural System [24]. National and international studies have emphasized the importance of IoT technology in system design, which not only improves the efficiency of the monitoring system, but also provides the possibility of remote control and data sharing. Nonetheless, current research still faces challenges such as cost-effectiveness, difficulty of deployment, and shortage of monitoring systems.

In addition, existing research is relatively lacking in integrating monitoring with actual physical protection measures. The application of catch net technology as a potential physical intervention in falling objects protection is still in the exploratory stage. Future research needs to address how to effectively integrate physical intervention devices, such as catch nets, with monitoring and warning systems to provide an all-encompassing safety protection solution.

1.5. Innovations and Challenges of This Thesis

The innovations in this thesis come from the following areas:

First, this thesis proposes a monitoring and warning system for falling objects using a combination of infrared sensors, a microcontroller unit (STM32), and an ESP32-CAM camera. With this combination, the system is able to realize real-time monitoring of falling objects and respond quickly when potential hazards may be detected, with faster processing speed and higher data accuracy than previous research.

Secondly, this study integrates an intelligent capture network in the system, which is capable of responding automatically in a short period of time based on the information from the detection and warning system in order to prevent falling objects from causing harm to people and property. This kind of automated physical intervention is relatively rare in previous studies and increases the practicality of this system.

Meanwhile, a Python-based simulation program is covered in the thesis for functional verification and performance evaluation at the early stage of system development. Thus, this system can initially confirm the rationality and efficacy of the system design before practical application.

Although this study has several technological innovations, it also faces a number of challenges. On the one hand, the stability and reliability of the system need to be continuously verified and optimized in long-term operation, especially the rapid response mechanism of the capture network, which must ensure that it can work reliably in various environments in real situations. On the other hand, the control of the system's warning false alarm rate is also a major challenge, which requires fine algorithms to differentiate between normal situations and potential dangers, so as not to cause unnecessary personnel commotion and waste of resources.

In addition, due to the integration of multiple technologies and complex hardware devices, the cost control of the system is also an issue that cannot be ignored. How to balance the performance and cost to produce a monitoring and warning system that is both economical and efficient will also be an important research direction of this project.

Taken together, this study is innovative in both theory and application, which is of great significance to improve the level of urban safety and protection. In the following paper, the above challenges will be discussed in depth and the system will be optimized, with a view to realizing a more perfect monitoring and early warning system for falling objects.

2. SYSTEM DESIGN PROCESS

2.1. System Programming

2.1.1. Overall concept and architecture of the system design

The monitoring and warning system for falling objects from height proposed in this study is based on the modularization idea so as to facilitate the independent operation of each part as well as the upgrading and maintenance at a later stage. The whole system is divided into three main modules: detection module, control module and response module. Figure 2-1 shows the design block diagram of the system.

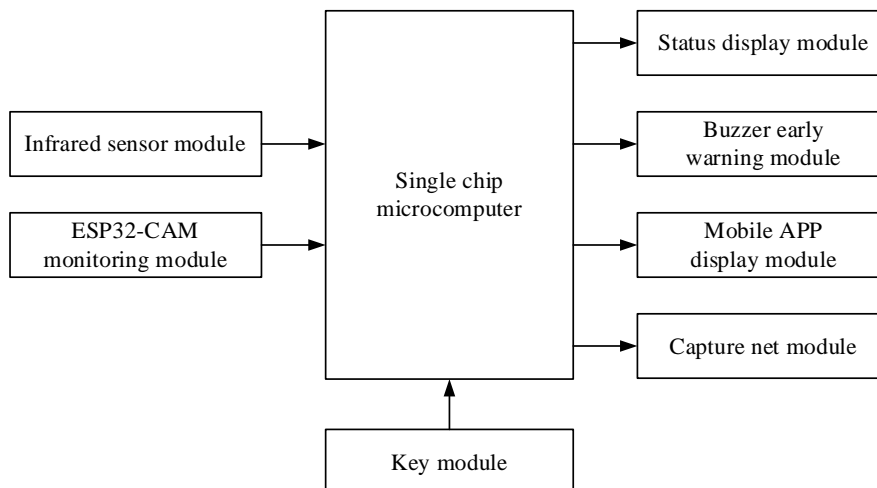

Figure 2-1. Block diagram of overall system design

Detection Module: Includes an infrared sensor module and the ESP32-CAM monitoring module. The infrared sensor is specifically responsible for detecting the movement of objects, when a potential falling object is detected, the sensor will immediately send a signal to the control module, while the ESP32-CAM monitoring module is used to capture dynamic images in the high altitude, and analyze

the size, speed and trajectory of the object through image processing technology, in order to prepare for the next step of the module's action.

Control Module: The control module is based on STM32 microcontroller as the core, which is responsible for receiving data from the detection module and making quick processing and decision according to the preset program. The module is also responsible for the logical processing of the control system, such as data synchronization, status monitoring and fault diagnosis.

Response Module: The response module includes the buzzer warning, status display, mobile app display module and automatically deployed and unfolded catch net module in the falling object warning system. The alarm system warns the surrounding people through sound. The catch net is a major innovation of this system, which can be automatically deployed in a short period of time to form a physical barrier to prevent falling objects from harming people on the ground.

The architecture of the system is designed to ensure fast response with high processing efficiency. All modules interact with each other through communication protocols designed to minimize delays and errors in data transmission and to ensure that the system operates reliably at critical times.

2.1.2. Role of the microcontroller and capture network function integration

In this system, STM32 microcontroller plays a crucial role, which is not only the heart of the control module, but also the brain of the whole falling object warning system. STM32 microcontroller has high-performance concurrent processing capability and rich peripheral interfaces, which enable it to efficiently manage the data from various sensors, perform complex data processing, and respond to real-time situations in a timely manner.

Specifically for this system, the microcontroller is first responsible for initializing all connected sensors and actuator modules, including the calibration of infrared sensors and cameras as well as the deployment of capture nets. During system operation, the microcontroller receives sensor data in real time and quickly analyzes the object's motion characteristics and potential risks through built-in algorithms. When it determines that there is a risk of falling objects, the microcontroller will issue commands to activate the alarm system and control the deployment of the capture net.

The integration of the capture net function is a major innovation in this study. The capture net is made of a high-strength, fast-deploying material that can be fully deployed within seconds to cover the potential area of the deployed falling object. By precisely controlling the deployment mechanism of the capture net, the microcontroller ensures that the net is fully deployed and ready for interception before the falling object reaches the ground. In addition, the microcontroller is responsible for monitoring the status of the net to ensure that it is always in optimal operating conditions and for troubleshooting and dealing with any anomalies that occur.

2.2. Hardware Design and Implementation

2.2.1. Configuration and role of the STM32F103C8T6 microcontroller

In this project, STM32F103C8T6 microcontroller is selected as the control core, which has the advantages of high performance, low cost and rich peripheral support, etc. STM32F103C8T6 belongs to the STM32F1 series of microcontrollers, which is based on the ARM Cortex-M3 core, with a maximum operating frequency up to 72 MHz, and features high-speed embedded memory (including 128 KB of Flash and 20 KB of SRAM) and a wide range of enhanced I/O ports and connectivity peripherals.

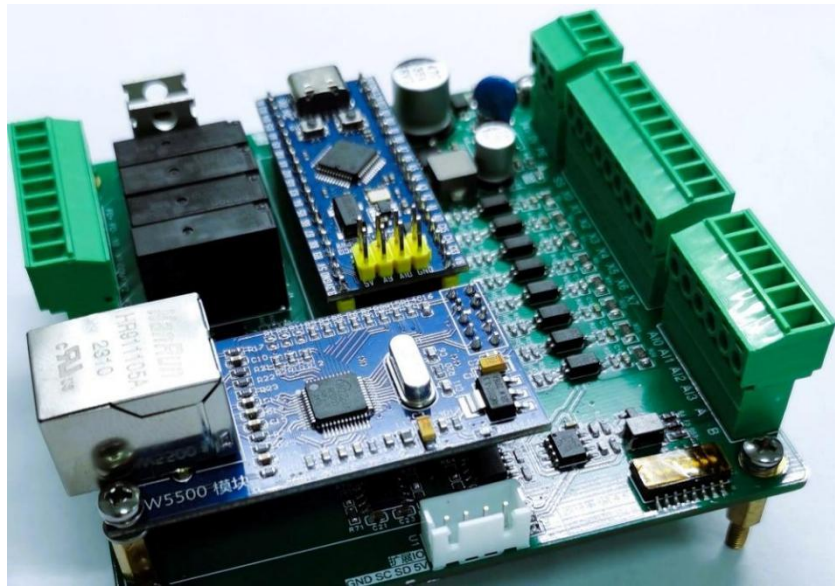

Figure 2-2. STM32F103C8T6 microcontroller

In this system, the STM32F103C8T6 assumes an important role in data collection, processing, and decision making. The STM32 microcontroller is configured with a variety of communication interfaces, such as I2C, SPI, and UART, which are used to exchange data with infrared sensors, ESP32-CAM cameras, and other monitoring devices. In addition, the STM32's multiple timer and ADC (analog-to-digital converter) input capabilities allow it to efficiently process analog signals from sensors and execute fast-response control commands.

The microcontroller in this project also directly controls the LEDs and buzzer through its PWM (Pulse Width Modulation) output function, which is used to perform the output of the alarm signal. This configuration allows the system to provide immediate visual and audible warnings to the surroundings when a falling object hazard is detected, thus increasing the effectiveness and timeliness of the alerts.

2.2.2. Integration and functionality of infrared sensors, buzzers, and LEDs

In this falling object monitoring and warning system, infrared sensors, buzzers and LEDs are the core hardware components to realize the monitoring and warning, and their precise integration and cooperation with the microcontroller are crucial to influence the effectiveness of the system.

Infrared sensors: infrared detection is widely used in construction, security, home appliances and industrial fields, according to its physical effects can be categorized as follows: according to the photoelectric effect of certain objects will be converted into electrical signals photon detection; according to the thermal effect of infrared heat will be converted into electrical signals thermal detector; equipment to emit infrared light across the cordon or through the diffuse reflection of the object by the receiver to be received by the receiver active infrared detection; Passive infrared detection in which the sensor collects the infrared signals radiated in from the outside world and converts them into electrical charge [13]. Passive Infrared Detection.

High sensitivity sensors are chosen for this project, the infrared module has a strong adaptability to the external environmental light, the probe consists of an infrared transmitter tube and an infrared receiver tube, the transmitter tube will regularly emit infrared rays with a fixed frequency during normal operation. When there is no object blocking, the receiver tube will output a high level. And when the receiver tube does not receive the infrared ray emitted by the transmitter tube, the output is low. Because of this design, the detection signal can be simply expressed in high and low levels, which is very convenient for signal transmission, so that it can be easily connected to a series of controllers such as microcontrollers [17]. The sensor can be easily connected to a series of controllers such as microcontrollers. The sensors are extremely sensitive to falling objects and can be activated as soon as the object passes through the detection area. The output of each sensor is connected directly

to the digital input pins of the STM32 microcontroller, configured in interrupt mode so that the microcontroller can process the signal in real time as soon as the sensor is triggered.

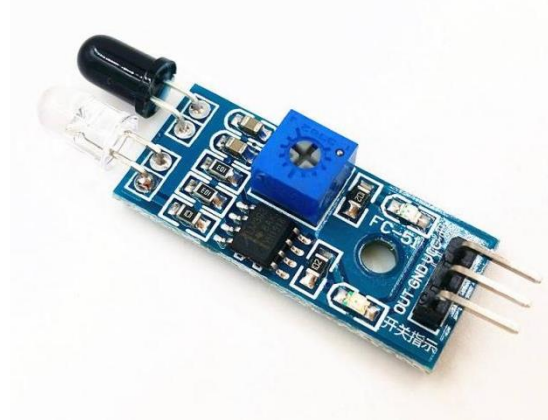

Figure 2-3. Infrared Sensor

Buzzer: The system uses an active buzzer and is low level triggered, whose main function is to emit a high decibel warning tone when a falling object risk is detected. The driver circuit of the buzzer is connected to one of the PWM outputs of the microcontroller and allows the system to adjust the volume and frequency of the warning sound according to the ambient noise level, ensuring that the warning sound can be effectively communicated in different environments.



Figure 2-4. Buzzer

LEDs: This system uses high brightness LEDs that can display different states to indicate the system status. For example, if the light is off, it means no danger has been sensed, and if the light is on, it means danger has been sensed. The control of the LEDs is also realized through the GPIO port of the STM32 microcontroller, and different blinking modes are programmed to convey different warning messages.

The integration of these components takes into account both circuit design optimization to minimize interference and increase response speed. In the system layout, infrared sensors are located at predefined strategic positions to cover as wide an area as possible, while buzzers and LEDs are set at easily recognizable locations to enhance the warning effect.

Through this careful design and configuration, the system is able to effectively monitor, provide timely warnings and interact with city residents through a user-friendly interface, greatly enhancing the system's utility and reliability.

2.2.3. Configuration of the ESP32-CAM Camera Module and Image Transfer Mechanisms

In this system, the ESP32-CAM camera module plays a key role, which is not only used to capture real-time images, but also involved in the detection and analysis of falling objects. The ESP32-CAM is a small but powerful camera module that integrates the ESP32 chip as well as a Wi-Fi module to enable image capture, which is ideal for use in applications that require remote monitoring and processing. applications. From the research of Li Qiu Hao et al. we learned that the traditional equipment is just a simple pure mechanical device or rigid structure, once the accident of falling

objects from height occurs, the management personnel can not know it at the first time, which will prolong the time of disposal of the accident, and may cause some irreparable losses. In the detection of falling objects can be the first time to remind the management personnel, as far as possible to minimize the losses caused by falling objects accidents, can improve the utilization value of the equipment [7].

Technical specifications and rationale for selection:

The ESP32-CAM is equipped with a 2-megapixel camera, which ensures that it has enough resolution to capture objects high in the sky in detail. And its built-in ESP32 chip supports Wi-Fi function, which can directly send the captured images to the central processing unit or cloud server via wireless network. In addition, the module supports a variety of sleep modes, which can effectively reduce power consumption and is suitable for outdoor applications that run for long periods of time.

Image Capture and Processing Flow:

The ESP32-CAM module in the system periodically captures high-resolution images of the area. Whenever a potential falling object is detected by the infrared sensor, the camera is triggered to immediately capture images of the area in question. These images are then sent to the STM32 microcontroller for initial analysis to determine if there is indeed a risk of falling objects. By analyzing the size, speed and falling trajectory of the object in the image, the system is able to accurately determine the threat level of the object.

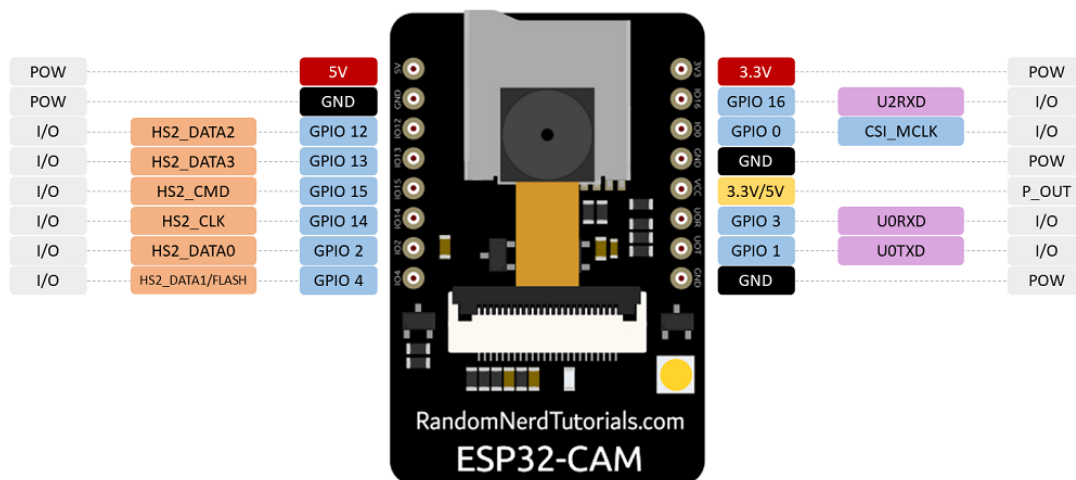

Figure 2-5. ESP32-CAM Camera Module

Implementation of the image transfer mechanism:

The ESP32-CAM module is capable of transmitting images in real time to a master unit on a LAN or uploading them to a server in the cloud via the Internet, using the built-in Wi-Fi function. This transmission process utilizes highly efficient compression algorithms to ensure fast and accurate transmission of image data, even under poor network conditions. The software at the back-end of the system further processes and stores the received images to support playback and analysis at a later stage.

This highly integrated image capture and transmission mechanism enables the system to provide real-time and accurate monitoring data, which enhances the real-time response and early warning capability of the falling object monitoring system. With these advanced technical configurations, the ESP32-CAM camera module provides solid technical support for the effective operation of the entire warning system.

2.2.4. Design of the capture net and its integration with the microcontroller

In a falling object monitoring and warning system, the design of the capture net is a key physical intervention to prevent falling objects from causing harm to people and property. The design and

implementation of this component is at the heart of the system's innovation, and this paper emphasizes the rapid deployment capability of the capture net.

The control mechanism is integrated with the microcontroller:

The rapid deployment of the capture net is directly controlled by an STM32 microcontroller. The microcontroller drives a dedicated motor to activate the folding and storage mechanism of the net. When the system detects the risk of falling objects, the microcontroller quickly commands the motor to release, enabling rapid deployment of the capture net.

Risk assessment and material survey:

During the development process, several rounds of material investigations and risk assessments were carried out for the capture net, taking into account the potential hazards of different environmental conditions in order to select the most suitable motor and design. These investigations have helped us to understand how different materials perform in extreme weather and usage conditions, thus ensuring that informed material choices can be made for real-world applications.

Through this comprehensive design review and rigorous material selection process, the protective capabilities of the catch net system were significantly improved, while enhancing the utility and reliability of the overall warning system. The successful implementation of this component marks an important innovation in falling object safety protection.

2.3. Circuit Design and Realization

2.3.1. Overall circuit design of the system

The core objective of the circuit design of this system is to create an efficient and reliable falling object monitoring and warning system. Its core component, the STM32F103C8T6 microcontroller, is connected to several sensors and actuators, and a high degree of functional integration is achieved through well-designed circuitry.

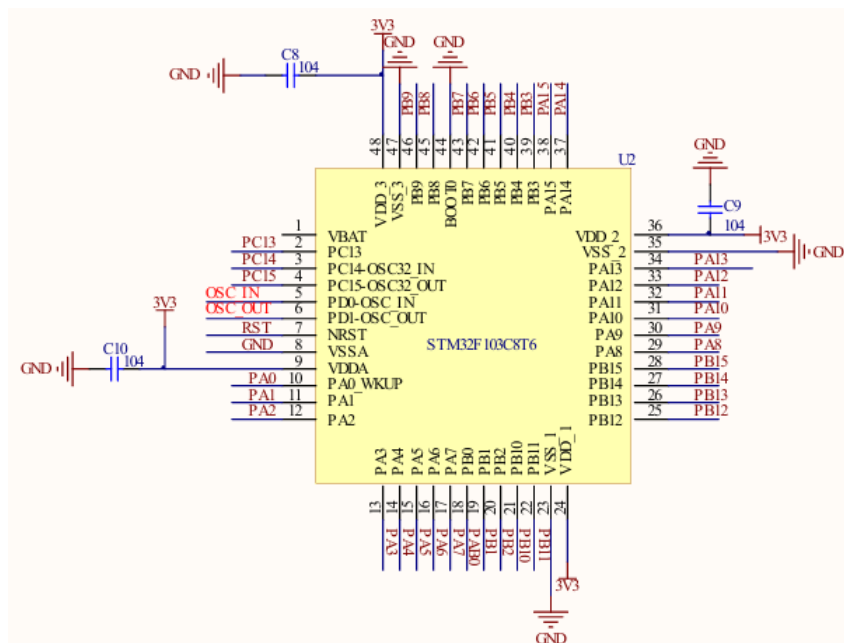

sensors, buzzers, LEDs, etc. through its wide range of I/O ports to support a wide range of data acquisition and status feedback.

(2) Sensor Interface: The system integrates several high sensitivity infrared sensors, which are responsible for real-time monitoring of potential falling object movements. The sensor signals are fed into the GPIO (input) port of the microcontroller through an analog interface, ensuring real-time and accurate data.

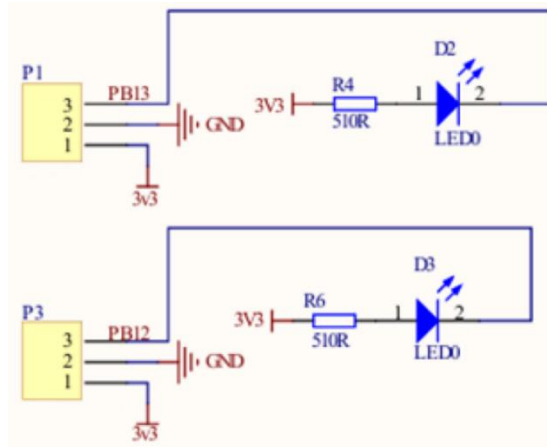

Figure 2-7. Infrared Sensor Module Circuit

(3) Actuator: The alarm system (including buzzer and LEDs) is controlled by the PWM port of the microcontroller for audio and visual cueing of the alarm.

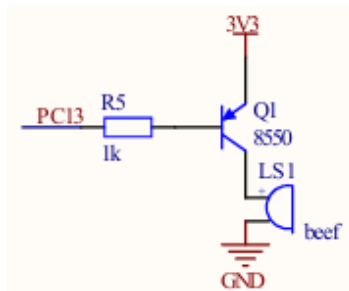

Figure 2-8. Buzzer Alarm Circuit

(4) Communication function: The ESP32-CAM camera module is connected to the microcontroller through a high-speed GPIO interface to ensure fast processing of image data. The system is also equipped with Wi-Fi function to support remote transmission of image data to the microcontroller.

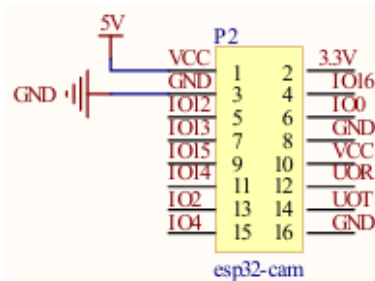

Figure 2-9. ESP32-CAM Camera Module Circuitry

(5) Power supply system: The system is designed to use the USB port for power supply, including LDO (linear voltage regulator) to 3.3V, in order to adapt to the power supply conditions in different situations and to ensure stable operation of the system.

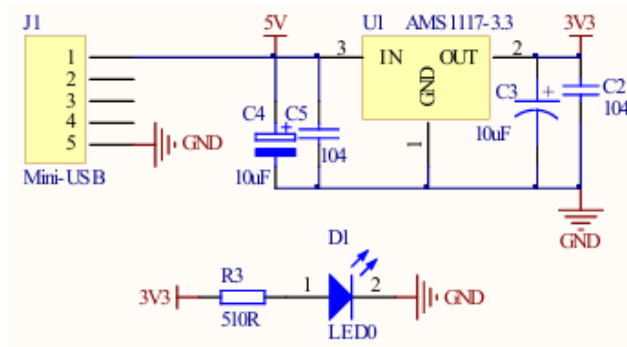

Figure 2-10. Power Supply Circuit

2.3.2. Detailed Analysis of Circuit Diagrams

Connection of the main control unit to other components: The STM32F103C8T6 microcontroller, as the central processing unit of the system, undertakes the important tasks of signal processing and decision making. The STM32 microcontroller is equipped with several general purpose input/output (GPIO) ports, the use of which is labeled in detail in the circuit diagram. The infrared sensor can be directly connected to these GPIO ports directly via digital signal lines, while the status of these ports is monitored in real time during the programming of the microcontroller to capture and process the signals received from the infrared sensor, thus realizing a fast response to the dynamics of the environment.

Camera Module Interface Connection: In the circuit diagram, the ESP32-CAM camera module is connected to the main control unit through an interface (GPIO). The GPIO interface responds quickly to ensure that the camera is able to transmit accurate image data to the processing unit, ensuring that the system is able to respond to external changes in a timely manner.

ALARM SYSTEM CIRCUIT: The design of the alarm system integrates a buzzer and LEDs, these components are driven through a pulse width modulation (PWM) port controlled by the microcontroller. We can control the volume of the buzzer and the brightness or blinking frequency of the LEDs by adjusting the duty cycle of the PWM signals for energy saving and optimal effectiveness of the alarm. In addition, the circuit includes resistor and transistor configurations to protect these sensitive components from damage caused by excessive current.

Power Management: The power section of the system is designed to take into account various power supply conditions, including careful voltage regulation and multiple protection mechanisms. The circuit diagram shows the detailed configuration of each voltage regulator and protection element to ensure stable operation of the system under different power input conditions and to protect the system from any voltage abnormality, thus prolonging the service life of the system and ensuring stable performance.

3. SOFTWARE DESIGN AND PROGRAMMING IDEAS

3.1. System Initialization

The first step in the programming of a falling object alarm system is to initialize the system's sensor actuators, which lays the foundation for the smooth operation of the entire system. The key task in this phase is to set up the hardware interface and communication protocols to ensure that the various components of the system can respond correctly to the control commands.

3.1.1. STM32F103C8T6 initialization

GPIO Configuration: The configuration of GPIO (General Purpose Input and Output Ports) is crucial to realize the system's external interactive functions. This project uses STM32F103C8T6 which

provides several GPIO ports which can be configured as input or output mode as required. In this system, I have configured some of the GPIO ports to be in input mode to receive signals from the infrared sensor, while others are configured to be in output mode for controlling the buzzer and LEDs. This configuration ensures that the system is able to respond appropriately based on the signals it detects, such as activating alarms or indicator lights.

Application code example:

```
void LED_Init(void)
{
    GPIO_InitTypeDef GPIO_InitStructure.

RCC_APB2PeriphClockCmd(RCC_APB2Periph_GPIOC|RCC_APB2Periph_GPIOB,ENABLE);
//Enable PC port clock

    GPIO_InitStructure.GPIO_Pin    =    GPIO_Pin_13|GPIO_Pin_14|GPIO_Pin_15;    //port
configuration
    GPIO_InitStructure.GPIO_Mode = GPIO_Mode_Out_PP; // Push-pull outputs
    GPIO_InitStructure.GPIO_Speed = GPIO_Speed_50MHz; //IO port speed is 50MHz
    GPIO_Init(GPIOC, &GPIO_InitStructure); //Initialize GPIOC according to set parameters
    GPIO_SetBits(GPIOC,GPIO_Pin_15); //output high
    GPIO_ResetBits(GPIOC,GPIO_Pin_13 |GPIO_Pin_14); //output low
}
```

This code initializes the peripheral components connected to the STM32F103C8T6 microcontroller. Specific GPIO ports are configured for output mode and initial states are set.

Serial Communication Configuration: Serial communication is a key channel for the system to exchange data with external modules (such as the ESP32-CAM camera module). By configuring the MCU serial port, the system can receive real-time image data from the camera or send control commands. This configuration requires setting the baud rate, data bits, stop bits and parity bits according to the actual needs to ensure the stability and accuracy of data transmission.

Clock and Interrupt Configuration: The system clock is essential to ensure that the microcontroller and its peripherals operate at a predetermined frequency. Reasonable interrupt configuration allows the microcontroller to interrupt the current task immediately upon the occurrence of external events (such as infrared sensor signals) and prioritize more urgent tasks. By accurately configuring the clock source and interrupt priority, the system is able to respond more sensitively and accurately to changes in the environment according to actual production requirements.

3.1.2. IR Sensor and Peripheral Configuration Initialization

In a falling object alarm system, the correct initialization configuration of the infrared sensors is critical to ensure that the system is able to effectively detect potential hazards. It is also equally important to initialize the settings of peripheral devices such as buzzers and LEDs, which provide the user with the necessary visual and audible feedback in the event of a hazard.

(1) Initialization of IR Sensor: IR sensor is the main tool to monitor the movement of objects in the environment. In this system, we configure the IR sensor precisely by code to capture all the important signals.

IR Sensor GPIO Connection Configuration: the output of each IR sensor needs to be connected to the specified GPIO input pins of the STM32F103C8T6. The code requires these pins to be configured in input mode in order to receive signals from the sensors. To ensure that the signals are read accurately, internal pull-up resistors need to be enabled for the GPIO pins. This ensures that the GPIO pins safely read high when the sensor is not active (output low or floating).

Application code example:

```
GPIO_InitTypeDef GPIO_InitStructure.
```

```
// Configure the GPIO for input mode to receive signals from the IR sensor
```

```
GPIO_InitStructure.GPIO_Pin = GPIO_Pin_x; // Replace x with the actual connected pin number
```

```
GPIO_InitStructure.GPIO_Mode = GPIO_Mode_IN_FLOATING; // set to float inputs
```

```
GPIO_Init(GPIOx, &GPIO_InitStructure); // replace x with the actual GPIO port
```

This code operates on the STM32's hardware platform registers and configures the General Purpose Input/Output (GPIO) ports in the microcontroller to receive signals from the Passive Infrared Sensor (PIR).

(2) Buzzer and LED Initialization: The buzzer and LED provide hazard feedback to the system user and are critical in indicating system status and warning the user of hazards ahead.

Buzzer Configuration: Since our buzzer is an active high level buzzer, it is necessary to configure a GPIO output port control for the buzzer, which is configured in output mode. The buzzer can be programmed to emit a sound under specific conditions, such as when the infrared sensor detects a falling object.

Application code example:

```
// Configure GPIOs for output mode for buzzer control
```

```
GPIO_InitStructure.GPIO_Pin = GPIO_Pin_y; // replace y with the pin number of the buzzer connection
```

```
GPIO_InitStructure.GPIO_Mode = GPIO_Mode_Out_PP; // Push-Pull Outputs
```

```
GPIO_InitStructure.GPIO_Speed = GPIO_Speed_50MHz; // Speed 50MHz
```

```
GPIO_Init(GPIOy, &GPIO_InitStructure); // replace y with the actual GPIO port
```

3. LED Configuration: The LEDs to be indicated are also connected to the GPIO output port and are configured in a similar manner to the buzzer. the LEDs are used to provide an indication of the system status.

Application code example:

```
// Configure GPIOs for output mode for controlling LEDs
```

```
GPIO_InitStructure.GPIO_Pin = GPIO_Pin_z; // Replace z with the pin number of the LED connection
```

```
GPIO_Init(GPIOz, &GPIO_InitStructure); // replace z with the actual GPIO port
```

```
GPIO_SetBits(GPIOz, GPIO_Pin_z); // turn on LEDs
```

3.1.3. ESP32-CAM Initialization

The initialization of the ESP32-CAM module mainly includes program burning, network configuration and image transmission settings. First of all, it is necessary to burn the program with preset Wi-Fi settings into the ESP32-CAM module, which is mainly responsible for setting the Wi-

Fi function of the module. Users can receive real-time image data from the ESP32-CAM after connecting to the Wi-Fi network through their cell phones.

Network Connection and Camera Module Configuration: Configure the Wi-Fi interface on the ESP32-CAM module to ensure that the device can connect to a cell phone or other smart device via a wireless network. In addition, detailed camera settings, including adjusting resolution and frame rate parameters, are required to optimize image clarity and smoothness to meet the technical requirements for real-time video surveillance.

3.2. Write the Main System Program Flow

In this section, we detail the running flow of the main program, which is designed to implement an infrared sensor-based monitoring system. The core functions of the main program include continuously monitoring the status of the two infrared sensors, controlling the LEDs to light up or not based on the feedback from the sensors, and triggering a buzzer alarm under specific conditions. Also included is a control program for the ESP32-CAM module, which controls the module's ability to capture images and transfer data in real time to the mobile application. The control logic of the whole process is realized through the GPIO interface, which ensures the sensitivity and responsiveness of the system. By describing the process in this chapter, the reader can clearly understand how the various components work together and how the hardware is controlled by the software to respond to external signals.

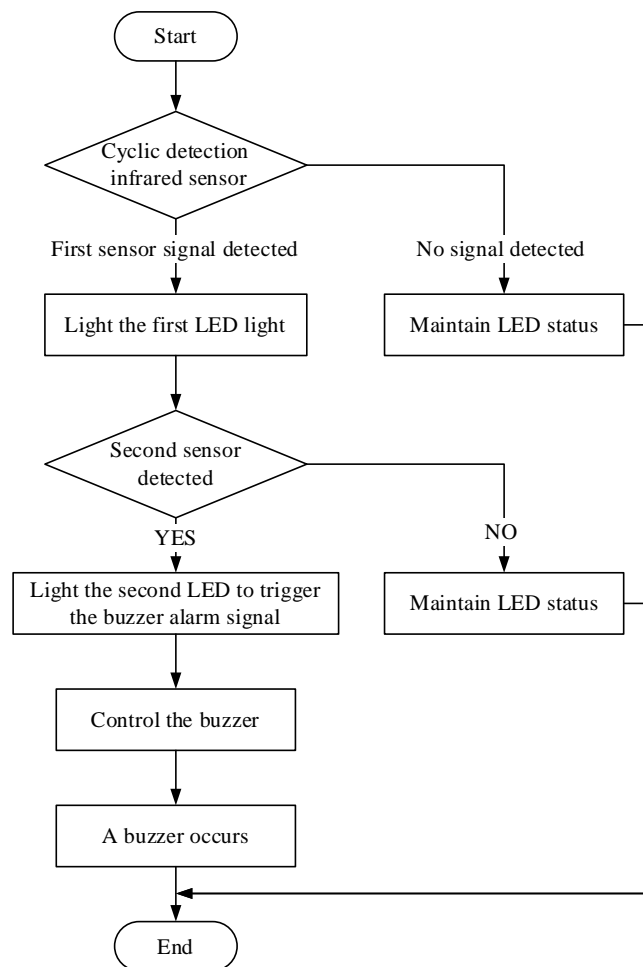

Figure 3-1. Flowchart of Cyclic Detection Program

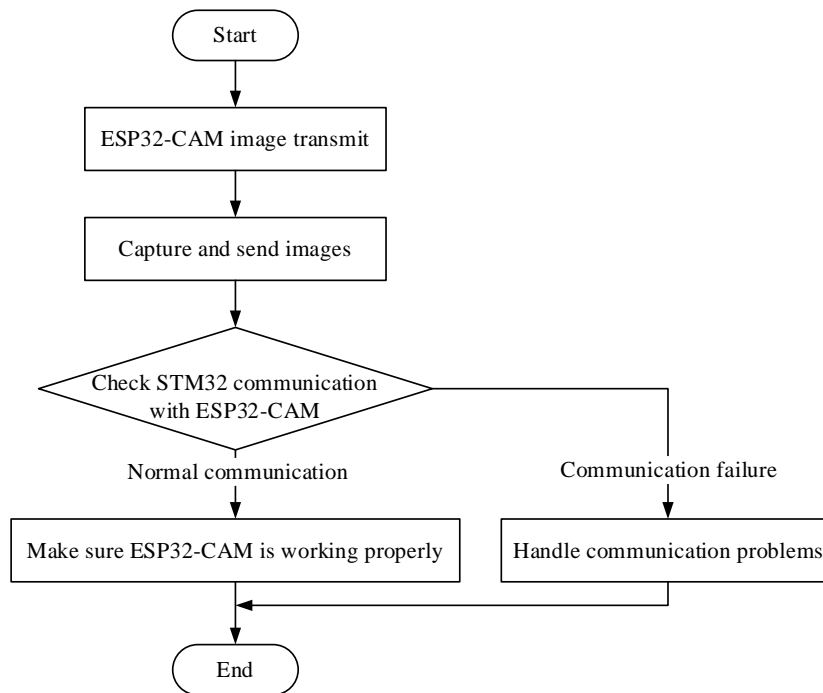

Figure 3-2. ESP32-CAM Image Transfer Flowchart

3.2.1. Cyclic infrared sensor detection

In a falling object warning system, continuous monitoring by infrared sensors is a core requirement to ensure that the system can provide effective warning. This part of the programming involves accurately processing the input signals from two independent infrared sensors and controlling the output of the warning signals accordingly, including the illumination of the LEDs and the activation of the buzzer.

(1) Design of cyclic monitoring logic: In the main program loop of the system, an important task is to continuously read the status of each infrared sensor. This process involves continuously monitoring the outputs of two sensors to determine whether a falling object has passed through the monitoring area. Based on this, the system realizes the response to a potential falling object event through the following steps:

a) Continuous Condition Monitoring: The system runs in an infinite loop to detect the output of each IR sensor in real time. This design ensures that the system is able to detect objects in a timely manner and respond within the first hour while the program is running the cycle.

while(1)

```

{
    readSensorStatus();
    processDetectedSignals();
}
  
```

(b) Conditional judgment and response: When the first infrared sensor detects an object passing by (i.e., the output signal of the first sensor goes low), the system lights up the first LED as a preliminary warning. If the second infrared sensor also detects an object immediately afterward, the buzzer is activated to sound a more urgent alarm while the second LED is lit.

if(sensor1Detected())

```

{
    LED1_ON();
  
```

```

if(sensor2Detected())
{
    LED2_ON();
    buzzerTrigger().
}
}

```

Alarm logic split between the two sensors ensures that the system can crank up the level of alarm based on the falling status of the obstacle to more accurately determine potential falling object threats.

3.2.2. Controlling the buzzer

In a falling object alarm system, buzzers are key output devices that provide the necessary warning function to warn people of potential danger. This section will discuss in detail how the behavior of these devices can be programmed and controlled to ensure that they are able to function at critical times.

The following is the control logic regarding the buzzer. The system activates or deactivates the buzzer by controlling the high and low levels of the GPIO port.

(1) Basic control logic: when the system detects an emergency situation (e.g., an object passes through both infrared sensors), it will activate the buzzer immediately. the STM32 microcontroller sends a high level signal to the GPIO port, and the buzzer starts to sound when it receives the high level, and the duration is controlled according to the time delay function.

(2) Example of dynamic control:

BUZZER RING DURATION: In some cases, a continuous buzzer may be more effective than an intermittent one. The buzzer ringing pattern and duration can be programmatically adjusted based on the severity of the environment or event.

```

void controlBuzzer(int duration) {
    GPIO_SetBits(GPIOx, BUZZER_PIN); // activate buzzer
    delay(duration); // delay function, keep ringing for a certain amount of time.
    GPIO_ResetBits(GPIOx, BUZZER_PIN); // turn off the buzzer
}

```

```

void controlLED(int ledNumber, int mode) {
    switch(mode) {
        case FLASHING.
            flashLED(ledNumber); // call the blink function
            break;
        case STEADY.
            GPIO_SetBits(GPIOx, ledNumber); // Continuously on
            break;
    }
}

```

3.2.3. Controlling LEDs

In a falling object alarm system, LED lights, as important visual feedback devices, are tasked with communicating system status and alarm information to the user. This section will explore in detail how to control the LEDs by programming them to ensure a timely response when signals from the infrared sensor are detected, and adjusting the LED status according to the alarm level to provide consistent and accurate feedback.

The system includes two LEDs, which correspond to the detection results of two infrared sensors. The lighting and state keeping of each LED is controlled by the microcontroller through the GPIO port, and the following is the specific control logic:

(1) Response of the first infrared sensor detection signal: when the first infrared sensor of the system detects an object passing by, it will immediately send a signal to the STM32F103C8T6 microcontroller. Upon receiving this signal, the microcontroller will set the corresponding GPIO port to high, which in turn will light up the first LED to provide an initial warning to pedestrians.

(2) Response of the second infrared sensor: If the second infrared sensor also detects the object, it indicates that the object is still moving in the monitoring area, and then the system needs to provide a stronger warning signal. Therefore, the STM32F103C8T6 microcontroller will again output a high level signal to another GPIO port to light up the second LED.

In some cases, if an object does not pass two sensors in a row, the system should keep the state of the first LED unchanged instead of false alarms or canceling existing warnings. This requires the program to be able to determine the movement of the object and control the state of the LEDs accordingly.

The following sample code snippet that implements the above logic shows how to control the LED lighting and state holding through conditional judgment and GPIO operation:

```
void updateLEDStatus() {
    if (sensor1Detected()) {
        GPIO_SetBits(GPIO_PORT, LED1_PIN); // light the first LED
        if (sensor2Detected()) {
            GPIO_SetBits(GPIO_PORT, LED2_PIN); // light the second LED
        }
    } else {
        // If the first sensor does not detect a signal, the status of the second sensor determines whether
        the first LED is maintained or not
        if (!sensor2Detected()) {
            GPIO_ResetBits(GPIO_PORT, LED1_PIN); // turn off the first LED if the second one
            also has no signal
        }
    }
}
```

3.2.4. Control of capture nets

In this Falling Object Alert System, the control of the catch net is a key safety feature that aims to reduce the risk of injury to pedestrians on the ground by physically guarding the net to stop or slow down falling objects. This section of the paper will explore in detail how the control logic for opening the catch net is designed and implemented.

The control of the catch net in this system consists of several key components: sensor inputs, microcontroller processing logic, and motor control. Below are the details of how these components function and work together:

(1) Sensor input: The system utilizes a set of infrared sensors to detect potential falling objects. When two or more sensors detect a falling object consecutively, the system treats this as a falling object confirmation.

(2) Microcontroller control logic: when the system confirms that the object is a falling object, the microcontroller will immediately send a signal to the motor controller.

(3) Motor-controlled capture net deployment: the motor controller receives the start signal from the microcontroller and activates the drive motor, which rapidly deploys the capture net to capture the falling objects.

Sample code:

```
void deployCatchNet() {  
    GPIO_SetBits(GPIO_PORT, MOTOR_CONTROL_PIN); // Send a high level signal to the  
    motor controller  
    delay(1000); // delay to make sure the motor is fully activated  
    GPIO_ResetBits(GPIO_PORT, MOTOR_CONTROL_PIN); // Turn off the signal to complete  
    deployment  
}
```

3.2.5. ESP32-CAM Image Transfer

For this project, the falling object alarm system not only sends out timely alarms, but also needs to record the on-site situation for subsequent analysis and processing. Therefore, the image transmission function of the ESP32-CAM module is a key component of the system for this project, which provides a real-time visual monitoring mechanism to enhance the monitoring capability of the system. This section will discuss in detail the configuration of the ESP32-CAM, the communication implementation with STM32, and the image data processing flow in the system.

ESP32-CAM Independent Operation and Image Transmission: The ESP32-CAM module integrates Wi-Fi functionality and a high-performance camera, enabling it to operate independently of the main control unit (STM32), continuously capturing and transmitting image data in real time. This reduces the burden on the STM32 microcontroller, allowing it to focus on sensor signal processing and alarm control.

Before starting the communication with STM32, network configuration and data transmission is required to configure the Wi-Fi interface of ESP32-CAM to connect to the LAN in order to transmit data to the mobile app for monitoring.

3.3. System Design Considerations

3.3.1. Infrared sensor signal processing

In a falling object warning system, an infrared sensor is one of the key components, which is responsible for detecting potential falling object events. However, infrared sensors may be falsely triggered in practical applications due to environmental disturbances or movement of other non-target objects. In order to improve the accuracy and reliability of the system, the signals from the sensors must be processed appropriately to minimize false triggering. This section discusses in detail how to optimize the signal processing of IR sensors through de-jittering logic and timers or interrupts.

(1) Infrared sensor signal jitter problem

Reason: Infrared sensors work by emitting infrared rays and receiving the signals reflected back, and the sensor determines the presence of an object based on the changes in the signals. However, factors such as dust, light changes, and temperature fluctuations in the environment may cause the signal to jitter, i.e., the signal changes repeatedly within a short period of time, making the microcontroller unable to accurately reflect the true state of the object.

Impact: Signal jitter can lead to system misinterpretation, e.g., mistaking ambient noise for falling objects, which triggers false alarms, affecting the reliability of the system and potentially causing unnecessary panic for pedestrians.

(2) De-jittering logic for infrared sensors

"De-dithering" is a commonly used technique in electronic signal processing, mainly used to eliminate transient signal fluctuations caused by poor contact or electrical noise. In the application of infrared sensors, de-jittering can effectively avoid false triggering due to environmental factors (such as wind, rain, etc.).

When the IR sensor first detects an object, it does not react immediately, but initiates a short delay (e.g. 10 ms). If at the end of this delay the sensor still detects the object, the system only considers it a valid trigger event. This is the de-jittering principle applied in this project.

a) De-jittering realization:

The setup code implements a short delay after receiving a trigger signal to check if the signal persists. This can be programmed as follows:

```
u8 KEY_Scan(u8 mode)
{
    static u8 key_up=1; //key release flag
    if(mode) key_up=1; //support consecutive presses
    if(key_up && (KEY1==0))
    {
        delay_ms(10); //de-jitter delay
        key_up=0;
        if(KEY1==0) return 1; //If the signal is still detected, return 1 to indicate valid triggering
    }else if (KEY1==1) key_up=1 ;
    return 0; //no key pressed
}
```

This code snippet shows how to implement basic de-jittering logic to ensure that the IR sensor's signal is triggered by actual object movement and not by incidental interference.

b) Detection of infrared sensor status changes using timers or interrupts

In addition to adding de-jittering logic at the code level, using timers or interrupts to continuously monitor the status of the IR sensor is an effective way to improve detection accuracy.

(3) Timer:

A microcontroller timer is configured in the program to periodically check the output state of the IR sensor. This approach allows the system to go to different points in time to quickly capture the state of the sensor, thus obtaining more coherent and detailed information about the movement of the object.

(4) Interrupt-driven methods:

Respond to changes in sensor status by configuring an interrupt service routine. Triggering an interrupt when the sensor output shifts from high to low or low to high allows the system to process these changes instantly, thus updating the system state in real time.

With these technologies, the system not only reduces false triggering of infrared signals, but also enhances the ability to monitor changes in the environment while maintaining speed of response. This is critical to the operation of a falling object warning system.

3.3.2. Buzzer and LED control logic optimization

In a falling object warning system, buzzers and LEDs are not only used as output devices to provide basic warning functions, but their behaviors also need to be finely tuned according to the system's specific application environments and warning needs. This section of the paper will discuss in detail how to optimize the control logic of buzzers and LEDs according to actual needs, such as adjusting parameters like the blinking frequency of LEDs and the ringing duration of buzzers.

(1) LED blinking frequency adjustment:

The blinking frequency of the LEDs can affect human attention and the perceived level of urgency. Adjusting the blinking frequency of the LEDs in real time via PWM parameters at different alert levels can help convey the correct warning message. For example, a high-risk alert can be set to flash rapidly, while a low-level warning uses slow blinking or steady illumination.

The blinking frequency is adjusted by setting the PWM duty cycle in the microcontroller through a programming method to control the switching cycle of the LEDs. The following sample code shows how to implement adjustable LED blinking control:

```
#include "stm32f10x.h"

// Initialize PWM function
void PWM_Init(uint16_t period, uint16_t prescaler) {
    TIM_TimeBaseInitTypeDef TIM_TimeBaseStructure.
    TIM_OCInitTypeDef TIM_OCInitStructure.
    GPIO_InitTypeDef GPIO_InitStructure.

    // Enable GPIOA, TIM2 clocks
    RCC_APB2PeriphClockCmd(RCC_APB2Periph_GPIOA | RCC_APB2Periph_AFIO,
ENABLE);
    RCC_APB1PeriphClockCmd(RCC_APB1Periph_TIM2, ENABLE);

    // Set GPIO mode to multiplexed push-pull outputs
    GPIO_InitStructure.GPIO_Pin = GPIO_Pin_1;
    GPIO_InitStructure.GPIO_Mode = GPIO_Mode_AF_PP;
    GPIO_InitStructure.GPIO_Speed = GPIO_Speed_50MHz;
    GPIO_Init(GPIOA, &GPIO_InitStructure);
}
```

```

// Initialize the timer
TIM_TimeBaseStructure.TIM_Period = period;
TIM_TimeBaseStructure.TIM_Prescaler = prescaler;
TIM_TimeBaseStructure.TIM_ClockDivision = 0;
TIM_TimeBaseStructure.TIM_CounterMode = TIM_CounterMode_Up;
TIM_TimeBaseInit(TIM2, &TIM_TimeBaseStructure).

// Initialize PWM channel 2 of TIM2
TIM_OCInitStructure.TIM_OCMode = TIM_OCMode_PWM1;
TIM_OCInitStructure.TIM_OutputState = TIM_OutputState_Enable;
TIM_OCInitStructure.TIM_Pulse = period / 2; // set the duty cycle to 50%
TIM_OCInitStructure.TIM_OCPolarity = TIM_OCPolarity_High;
TIM_OC2Init(TIM2, &TIM_OCInitStructure).

TIM_Cmd(TIM2, ENABLE); // enable TIM2
}

// Adjust the duty cycle of the PWM to change the brightness of the LEDs
void Adjust_LED_Brightness(uint16_t pulse) {
    TIM_SetCompare2(TIM2, pulse); // change duty cycle
}

// Use PWM to control LEDs in the main function
int main(void) {
    SystemInit().
    PWM_Init(999, 71); // Assuming a timer period of 1000-1 and a prescaler factor of 72-1, generate
a 1KHz PWM frequency
    while (1) {
        for (int i = 0; i < 1000; i += 20) {
            Adjust_LED_Brightness(i).
            delay(10);
        }
    }
}

```

(2) Adjustment of buzzer ringing duration:

Similarly the buzzer's ringing duration can be adjusted according to the urgency of the alarm, with longer rings usually used for more urgent situations and shorter rings for less urgent alerts.

Similar to LEDs, the buzzer can be controlled by adjusting the PWM duty cycle.

4. SYSTEM TESTING AND SIMULATION ANALYSIS

4.1. Overall Testing and Problem Analysis

The Falling Object Alarm System is an overall system and needs to be tested according to the functions required to be realized during testing. See if the overall functional logic is correct.

First test in the first infrared sensor detected falling objects but the second did not detect, should only corresponding to the first led light, the rest of the module does not respond. The test results are shown in Figure 4-1.

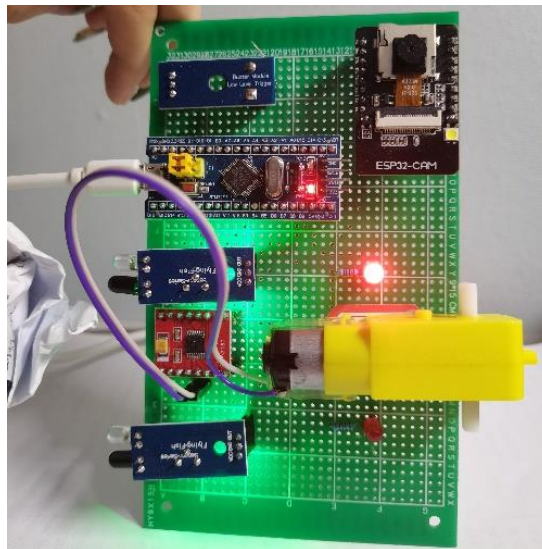

Figure 4-1. The first infrared sensor detects an object

The second test in the second sensor senses the falling object, the corresponding led light on, buzzer alarm, motor start, at this time, the first led light off. Test results are shown in Figure 4-2.

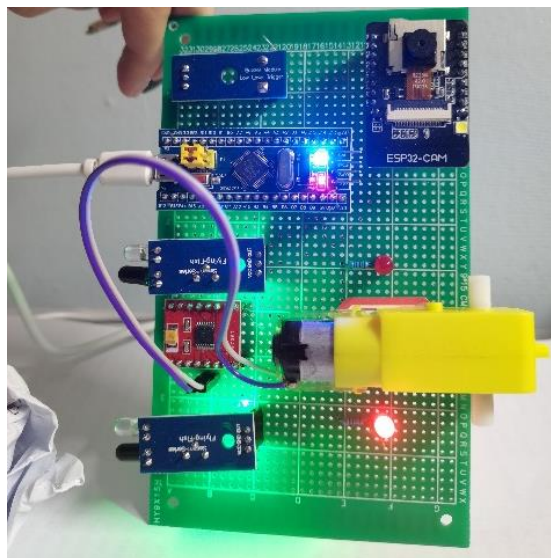

Figure 4-2. Second infrared sensor detects an object

Finally, the ESP32-CAM related functions are tested. First, use your cell phone to make a connection to the specific Wi-Fi, then open the APP and click on the connected device, and the ESP32-CAM real-time monitoring screen will be displayed. The test results are shown in Figure 4-3.



Figure 4-3. ESP32-CAM Camera Content Monitoring

In this design, there were various issues that arose during the overall system testing and the following is a specific analysis of the main issues.

In the early stages of the physical test, after powering up appeared in the absence of any falling objects, all the reaction module is running, is to show that the system at this time is in the two sensors are sensing falling objects, after testing and analysis, the problem is judged to be in the sensors, remove the two infrared sensors for the sensitivity of the debugging, reinstalled, the system reflects the normal. This situation may be due to the sensor sensitivity in different light under different reasons

In the late debugging, when the cell phone connects to Wi-Fi, it will show connection error or wrong password, after consulting the relevant information, re-plugging and connecting to the board, or turning off the cell phone Wi-Fi and then re-opening it, both of which will show the success of connecting to Wi-Fi. This is because sometimes the voltage of the Wi-Fi module is unstable, or the cell phone will automatically choose the Wi-Fi with strong signal to connect. So we need to choose a steadier voltage or turn off the cellular Wi-Fi to optimize it.

4.2. Brief Description and Role of the Algorithmic Simulation Program

In order to optimize the subject and to be able to test it without using hardware, I applied an algorithmic simulation program to achieve the goal. The simulation program is written in Python language and mainly utilizes OpenCV and Numpy libraries to process the falling object images and video data to perform target detection and tracking functions. This program is a visual alert for falling objects, which detects and tracks objects in the air through detailed image analysis and feature extraction. The key components and functions of the program are described in detail below:

4.2.1. Image Preprocessing and Feature Extraction

(1) Pre-processing: load the initial image and initialize the key parameters of the image by resizing and applying ORB feature detection algorithm.

(2) Feature extraction: use the ORB algorithm to extract key points and corresponding feature points from the adjusted image, laying the foundation for subsequent feature matching.

```
class Adjuster.
```

```
    def __init__(self, start_image, edge=(60, 20)).
```

```
self.start_image=cv2.resize(start_image,(int(start_image.shape[1]/1),int(start_image.shape[0]/1)))
```

```
    self.descriptor = cv2.ORB_create()
```

```
(self.kps, self.features) = self.detectAndDescribe(self.start_image)
```

4.2.2. Feature Matching and Image Alignment

(1) Feature Matching: Matching of feature points by BruteForce method to find pairs in order to compute the transformation matrix between images (Homography).

(2) Image Transformation: The computed Homography matrix is applied to transform the image to correct image distortions caused by camera movement or vibration.

```
def debouncing(self, image, ratio=0.7, reprojThresh=4.0, showMatches=False).
    image = cv2.resize(image, (int(image.shape[1]/1), int(image.shape[0]/1)))
    (kps, features) = self.detectAndDescribe(image)
    M = self.matchKeypoints(kps, self.kps, features, self.features, ratio, reprojThresh)
    if M is None: If M is None.
        return None
    (matches, H, status) = M
    result = cv2.warpPerspective(image, H, (image.shape[1] + image.shape[1], image.shape[0] +
image.shape[0]))
    result = result[int(self.edge[1]): int(image.shape[0] - self.edge[1]),
                    int(self.edge[0]):int(image.shape[1] - self.edge[0])]
    return result
```

4.2.3. Target detection and tracking

(1) Image background subtraction: using the KNN background subtraction algorithm, which can effectively separate the foreground (moving objects) from the background, facilitating the detection of moving objects in the video and improving the recognition rate.

(2) Applying Morphology to Optimize Images: Morphology open and swell operations are applied to optimize the foreground mask, remove noise generated by the background subtraction algorithm, and enhance the target contour.

```
class knnDetector.
```

```
    def __init__(self, history, dist2Threshold, minArea).
        self.minArea = minArea
        self.detector = cv2.createBackgroundSubtractorKNN(history, dist2Threshold, False)
        self.kernel = cv2.getStructuringElement(cv2.MORPH_ELLIPSE, (5, 5))
```

```
    def detectOneFrame(self, frame).
        mask = self.detector.apply(frame)
        mask = cv2.morphologyEx(mask, cv2.MORPH_OPEN, self.kernel)
        mask = cv2.morphologyEx(mask, cv2.MORPH_DILATE, self.kernel)
```

```
contours,hierarchy=cv2.findContours(mask,cv2.RETR_EXTERNAL,cv2.CHAIN_APPROX_SIMPLE)
```

```
bboxes = [cv2.boundingRect(c) for c in contours if cv2.contourArea(c) >= self.minArea]
```

return mask, bboxes

4.2.4. Tracking algorithms

(1) Initialization and updating of the tracker: An online real-time tracking algorithm (SORT) is used, which combines Kalman filtering and the Hungarian algorithm (linear assignment problem) to provide efficient target tracking for moving objects. The Kalman filtering algorithm is utilized, which is a linear recursive filter for the search range of the moving target in the next frame. The Kalman filtering algorithm builds a state model of the moving target due to meeting the requirements of real-time processing and uses the state model to estimate the target's motion information in the next frame based on the moving target's current motion state information, which includes the moving target's velocity and Acceleration, i.e., the position of the moving target is predicted, which reduces the search range of the moving target and improves the computational efficiency, and also solves the problem that the target cannot be tracked due to local occlusion. Kalman filter has the advantages of simple model and small data storage, which is suitable for engineering applications. Based on the model of LiDAR tracking motion target, the KF algorithm is selected according to the research motion target is determined as a uniform linear motion in a small scanning area space [20]. KF (Kalman filter) algorithm is chosen.

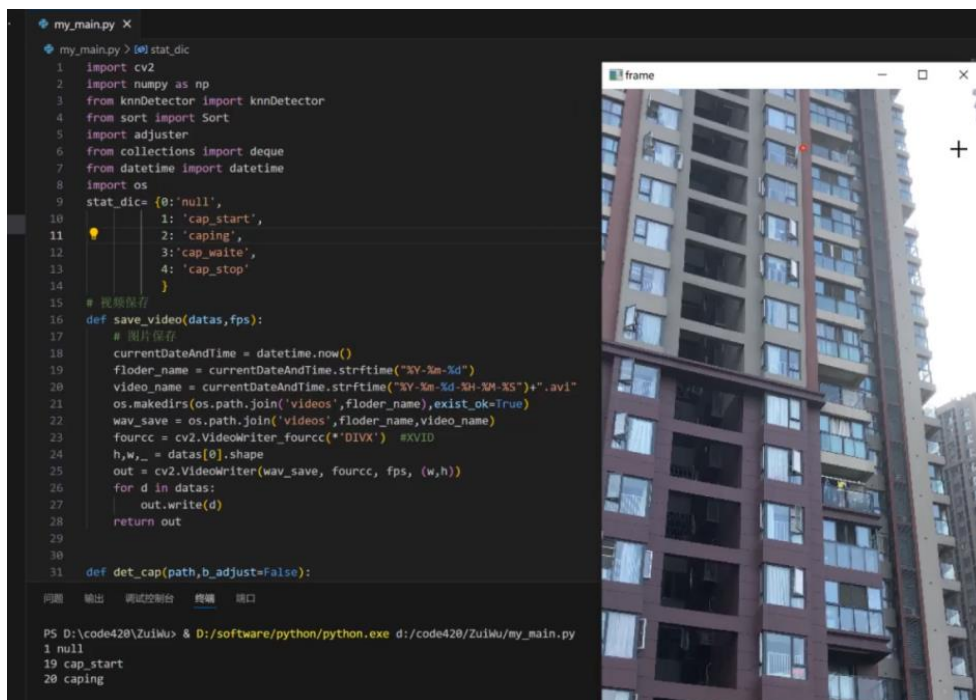

Figure 4-4. Falling Object Detection Simulation

(2) Target state prediction and updating: each tracking object maintains a state model, and the tracking state is maintained through prediction and updating steps, so that the appearance and disappearance of targets can be handled in real time to adapt to the rapid movement of falling objects.

class Sort.

```
def __init__(self, max_age=1, min_hits=3, iou_threshold=0.3).  
    self.trackers = []  
    self.max_age = max_age  
    self.min_hits = min_hits  
    self.iou_threshold = iou_threshold
```

```
def update(self, dets).  
    # Update the tracker and return the updated tracking target  
    return updated_trackers
```

4.3. Application Value of the Algorithmic Simulation Program

The design and implementation of the algorithmic simulation program is crucial to the development of this topic, the falling object warning system. The simulation programs not only support the simulation detection of the basic requirements of the system, such as real-time detection and tracking of airborne objects, but also provide technical support for the system at several levels, such as image preprocessing, feature extraction, and object detection and tracking. The following are a few key points where these simulation programs are linked to this topic:

(1) Real-time processing and performance requirements:

The subject requires a system that can quickly and accurately recognize objects high in the air under changing environmental conditions. The algorithm simulation program quickly detects and tracks objects by processing video streams in real time, which satisfies the high standard of the system for real-time warning of falling objects.

(2) Accuracy and Stability of Algorithms:

The algorithms in this simulation program, such as feature matching and target tracking algorithms, provide highly accurate and stable results in the face of falling objects. The application of these algorithms ensures that the system can effectively minimize false alarms and missed alarms and improve the overall reliability of the system when it is actually deployed.

(3) Scalability and foresight of technology:

The simulation program not only addresses current technical needs, but is also designed with future expansion and upgrading of the system in mind. For example, the modular design and parameterization of the algorithms included in the program make it easier to optimize or replace the algorithms in the future, supporting the long-term development of the subject.

(4) Ease of development and testing:

The algorithm simulation program allows us to perform extensive testing without the intervention of actual hardware. This not only speeds up the development cycle, but also reduces the development cost. At the same time, the simulation environment provides a safe testing platform on which researchers can try more innovative algorithms for this system.

The simulation can help to understand how the system works and provides a valuable reference for system optimization and improvement. In practical applications, it can improve the system's traceability. Through the simulation, various situations and scenarios can be modeled, including the occurrence and handling process of a falling object incident. In the actual situation, after the occurrence of the falling objects incident, through the analysis and verification of the simulation results, the relevant responsible parties can be held accountable according to the simulation results of the system, thus improving the efficiency and fairness of the accident handling.

5. SUMMARY

5.1. Summary of Research Results

5.1.1. Core Role of Microcontrollers and System Performance

In this project, the STM32F103C8T6 microcontroller plays the role of the nerve center of the system, which is responsible for integrating data from various sensors, executing control commands and processing signals. The efficient signal processing capability of the STM32F103C8T6 ensures that the system is able to respond to external events in real time according to the actual situation, and to quickly recognize and react to falling objects. This is crucial in the design of this system, as the processing speed directly affects the practicality and reliability of this alarm system. The high-performance parallel computing capability of the microcontroller allows the system to continuously process and analyze data from the infrared sensors, improving the overall response speed and accuracy of the system.

5.1.2. Integration and Functional Realization of Capture Nets

The addition of the catch net is a major innovation of this thesis, which not only increases the practical application capability of the system, but also improves the safety of the whole falling object alarm system. It ensures that the drive mechanism controlled by the microcontroller rapidly unfolds the catch net after confirming the detection of a falling object, and this action is realized thanks to the precise timing and control coordination between the microcontroller and the motor driver. This rapid response mechanism greatly improves the system's ability to protect against falling objects and minimizes possible injury or property damage. With the motor drive, the catch net can be fully deployed in a matter of seconds, providing excellent reliability and efficiency for the entire system.

5.1.3. Arguments for practical applications

In practical application, taking into account the actual wide range of falling objects, so in the installation of physical objects, need to be reasonably installed. The installation program is roughly horizontal arrangement on the floor, the specific system needs to be placed in the form of a matrix, which can reduce the possibility of falling objects falling from the area not covered by the sensor.

In this physical production, the infrared sensor used in this design can detect the angle of about 35 degrees, the detection distance is roughly 0.5 meters, through the investigation of the actual situation, the distance between the floor of the residential building is roughly 15 meters, under this condition, the following parameters can be calculated to determine the specific placement:

(1) Determination of sensor coverage

The formula for calculating the coverage is: $\text{horizontal coverage} = 2 \times \text{detection distance} \times \tan(\text{detection angle}/2)$

So, the horizontal coverage is $2 \times 0.5 \times \tan(17.5^\circ) \approx 0.3153$ meters

(2) Calculate the number of sensors needed

In order to cover a 15 meter wide floor, it is calculated that we need $15/0.3153 \approx 48$ sensors.

In summary, by calculating the parameters, the actual placement scheme of this design is to place a physical object every 0.3153 meters on the width of the floor until it covers a width of 15 meters. Then considering that the sensor detection distance is 0.5 meters, so it can be arranged vertically every 0.5 meters on this basis to ensure full coverage of the area.

When it comes to the actual placement, there are a few more things to keep in mind:

(1) Angle adjustment of physical sensors

It is important to ensure that the detection range of each physical sensor covers the edges of neighboring physical sensors both horizontally and vertically to avoid dead ends and blind spots.

(2) Height adjustment of physical sensors

Adjust the mounting height of the sensor appropriately so that it maximizes the coverage of the area where falling objects are likely to occur, taking into account the actual use and height of the floor.

With the above physical placement scheme, the falling objects on the whole floor can be effectively monitored, timely alarms can be issued, and the reliability and monitoring effect of the system can be improved.

5.2. Theoretical and Practical Implications

5.2.1. Contributions to urban safety management and practical implications

The falling objects alarm system developed in this project has significant theoretical and practical significance in urban safety management. With the acceleration of urbanization in China, there are more and more high-rise buildings, and the risk of falling objects incidents increases. The system is able to effectively monitor and warn potential falling object risks and, through the integration of real-time capture and alert functions, significantly improves the safety and security of urban residents.

And the deployment of the system can provide important support in the field of public safety, especially in densely populated urban areas. By reducing the occurrence of falling objects accidents, the resulting casualties and property losses can be effectively avoided or minimized, which is of great value and significance in enhancing the safety and livability of urban living. In addition, the implementation of the system also helps to improve the technological and informatization level of urban management, promote the development of China's smart city construction, and comply with the development needs of the new era.

5.2.2. Problems and directions for improvement

Although the falling object warning system in this paper has demonstrated a high level of reliability and effectiveness, there are still some problems and limitations in the actual real-world applications. For example, the adaptability of the system to environmental conditions such as rain and fog and other inclement weather has not been verified and still needs to be improved. In addition, the installation and maintenance costs of the system are also issues that need to be considered, and the economic benefits of widespread deployment need to be analyzed.

Therefore, in order to further improve the performance of the system, I believe that future research and development can consider the following directions:

(1) Improvement of sensing technology: Sensors with higher accuracy and greater robustness can be investigated to replace existing infrared sensors in order to improve the accuracy and reliability of the system under various climatic conditions.

(2) Optimize the code: Continue to optimize the logic code for data processing and analysis of the microcontroller to improve the system processing speed and reduce the false alarm rate.

(3) Analyzing cost-effectiveness: Conducting a detailed cost-benefit analysis to explore possible ways to reduce the costs of system deployment and operation and maintenance, and to improve the system's competitiveness in the marketplace.

5.3. Conclusion

Through the research and development of this project, the falling object alarm system has been basically successfully realized and has shown good performance in experiments and preliminary

applications. This paper overcomes a number of technical difficulties through innovative technical realization and system design, and provides strong technical support for urban safety management. The successful development of the system not only verifies the validity of the theory and technology of the related microprocessor to deal with falling objects, but also provides valuable practical experience and data support for related fields. In the future, with the further development and optimization of China's science and technology, the system will be applied in more scenarios to protect the safety of more urban residents.

REFERENCES

- [1] ZHANG Lei, LI Zicheng, WU Zhuo. Design and realization of STM32-based obstacle avoidance system for the blind [J]. Automation and Instrumentation, 2023, 38(12):110-113+117.
- [2] LIU Jingqi, FENG Xilong, ZHANG Bo Yong, ZHENG Wenqian. A monitoring system for overhead throwing based on ultrasonic detection and cloud IOT [J]. Technology and Innovation, 2023, (05):53-55+58.
- [3] Yang Jun. Design of high-altitude intelligent fall prevention planter based on STC89C52 [J]. Electronic Testing, 2021, (10):16-18.
- [4] Lv Yaohui, Lv Chenhui, Sui Jie, Yang Wenhai, Deng Zhouhu, Li Qiang. Design of intelligent detection and early warning system for falling objects [J]. Electronic Fabrication, 2021, (09):13-15.
- [5] SUN Jingwei, DING Xueyu. Design and realization of intelligent fan control system [J]. Information and Computer (Theoretical Edition), 2020, 32(19):85-88.
- [6] ZHANG Yu, HUANG Bangjin, CAI Yurun, MIAO Ying, WANG Jun. Intelligent monitoring system for overhead throwing based on ultrasonic and cloud IOT technology [J]. Electromechanical Engineering Technology, 2020, 49(09):105-106+119.
- [7] LI Qiuhaohao, JIA Xiaoqiang. Design and analysis of falling objects interception and forensics system [J]. Electronic Components and Information Technology, 2021, 5(8):47-50. DOI:10.19772/j.cnki.2096-4455.2021.8.021.
- [8] He Guangcheng. Design of high-altitude fall prevention system based on STM32 microcontroller [J]. Information Technology and Informatization, 2019, (11):56-59.
- [9] Zhou T. A falling object warning system for construction sites:CN201811485046.1 [P]. 2019-05-24.
- [10] Yu Duan, Weiguan Zhang, Zhengchun Peng. High Spatial Efficiency Single-particle Trapping Array Based on a Microfluidic Device [J]. IOP Conference Series: Materials Science and Engineering, 2019, 563(3).
- [11] Liu Yuchen. Design and realization of obstacle detection system for lawn mower [D]. Chongqing University, 2019.
- [12] XIA Changyu, CHEN Qian, ZHANG Kai. Detection system design of temperature, sound and distance detection module [J]. Microcontroller and Embedded System Applications, 2018, 18(08):31-34+38.
- [13] Qin Qinglei. Design of an ultra-low power infrared obstacle detection module [J]. Electronic Fabrication, 2017, (07):15-16.
- [14] N C Ryder. Microcontroller Based Data Acquisition System for Silicon Photomultiplier Detectors [J].
- [15] Shakeel Akram, Farhan Hameed Malik. Microcontroller Based Single Axis Intelligent Control Sun Tracker for Parabolic Trough Collectors[J]. Advanced Materials Research,2012,1917(562-564):1772-1775
- [16] An Overview of Initiatives to Cope with Throwing Objects from a Height in Various Places[J]. China Property Management, 2010(8):30-31.
- [17] WANG Nan, GAO Luliang, YANG Feng, et al. Vacant parking space management and guidance system based on infrared obstacle avoidance module and ARM Cortex-M3 [J]. Electronic World, 2016(23):111-112. DOI:10.3969/j.issn.1003-0522.2016.23.094.
- [18] LI Chenlei, ZHU De'an. Boundary of Legal Responsibility and Criminal Judicial Practice of Throwing and Falling Objects from a Height [J]. Journal of Taiyuan City Vocational and Technical College, 2023(1):201-204. DOI:10.3969/j.issn.1673-0046.2023.01.053.
- [19] ZHANG Xuelin. Who bears the responsibility for falling objects from a height and hitting a car [J]. JAC Rule of Law, 2023(21):45. DOI:10.3969/j.issn.1673-3088.2023.21.032.
- [20] LEI Zhongjun, ZUO Yuanzhong, TANG Deqian, et al. Research on human motion tracking in intelligent visualized fall prevention IoT system for aerial work [J]. Digital Communication World, 2018(9):110-111, 169. DOI:10.3969/J.ISSN.1672-7274.2018.09.089.
- [21] Guo Daojiu. New technology empowers fine urban governance [J]. Xiaokang, 2021, 461(8):80.
- [22] Zhu Xiaoqin. Design of a scene monitoring and recognition system [J]. Integrated Circuit Applications, 2021, 38(11):192-193. DOI:10.19339/j.issn.1674-2583.2021.11.090.

- [23] Wang Wenzhu. Key technology and application of overhead throwing monitoring system [J]. China Security Prevention Technology and Application,2021(4):29-31. DOI:10.3969/j.issn.1672-1470.2021.04.007.
- [24] XIN ZHANG. High-altitude anti-falling device [C]. //6th International Conference on Machinery, Materials, Environment, Biotechnology and Computer: MMEBC 2016, Tianjin, China, 11-12 June 2016, Part 3 of 3. of 3. Atlantis Press, 2016:1976-197